

# Flat moon suspension 450 down LED

133000XX\_133001XX\_133002XX\_133003XX\_133004XX\_133005XX

Scan for installation video or go to [supermodular.com/en/flat-moon/](http://supermodular.com/en/flat-moon/)

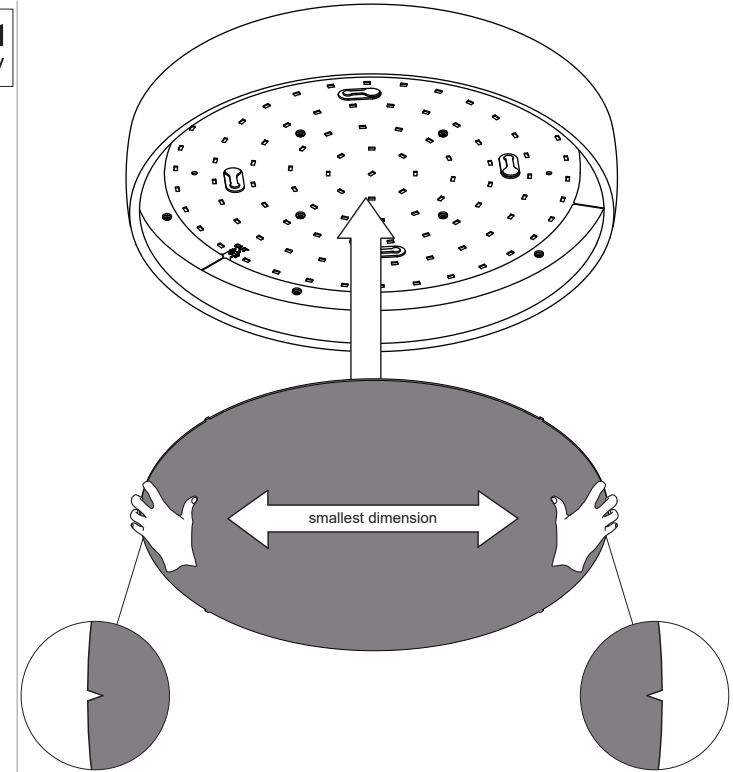
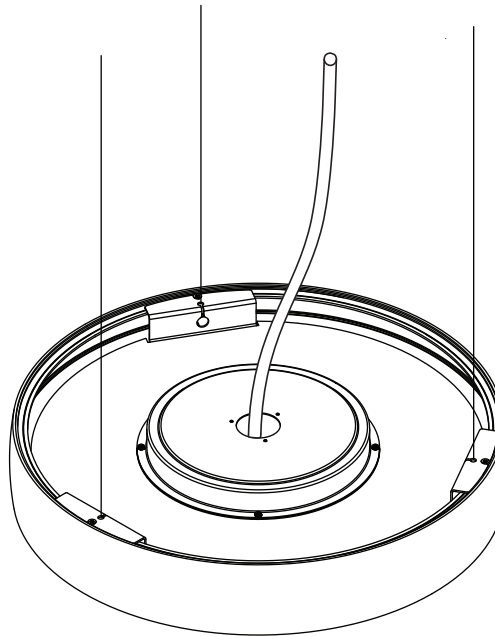
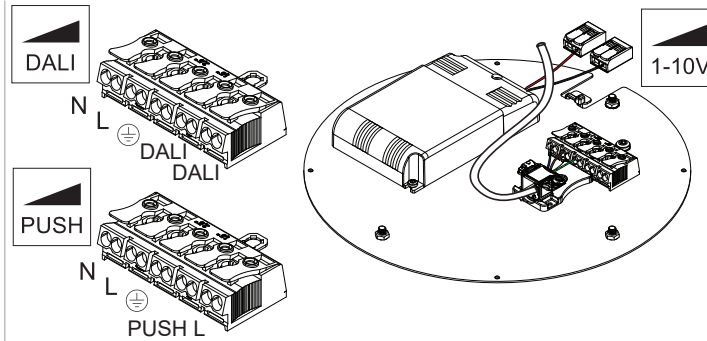
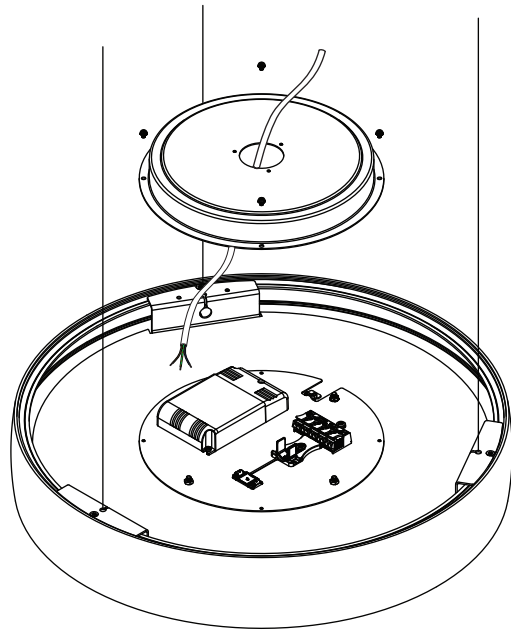
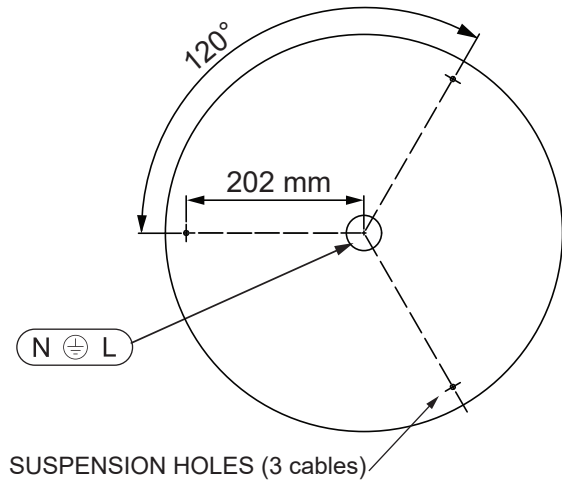

Be careful not to damage the LEDs when inserting the diffuser.

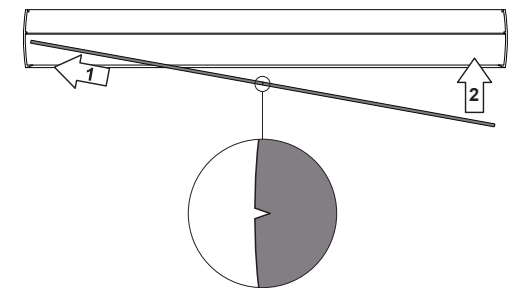

Replace protective shield when broken. The luminaire shall only be used complete with its protective shield. Reference number: 1012134



The light source contained in this luminaire shall only be replaced by the manufacturer or his service agent or a similar qualified person

