

Smart Cake/Kup/Lotis 115 (diffuse) IP54 LED DE

127403XX(-B1)_127404XX_127405XX_127420XX_127421XX_127422XX_127423XX_127424XX_127425XX_127426XX_127427XX_127428XX_127430XX_127431XX_127435XX_127503XX_127504XX_127505XX_127520XX_127521XX_127522XX_127523XX_127524XX_127525XX_127526XX_127527XX_127528XX_127530XX_127531XX_127535XX_127603XX_127604XX_127605XX_127620XX_127621XX_127622XX_127623XX_127624XX_127625XX_127626XX_127627XX_127628XX_127630XX_127631XX_127635XX

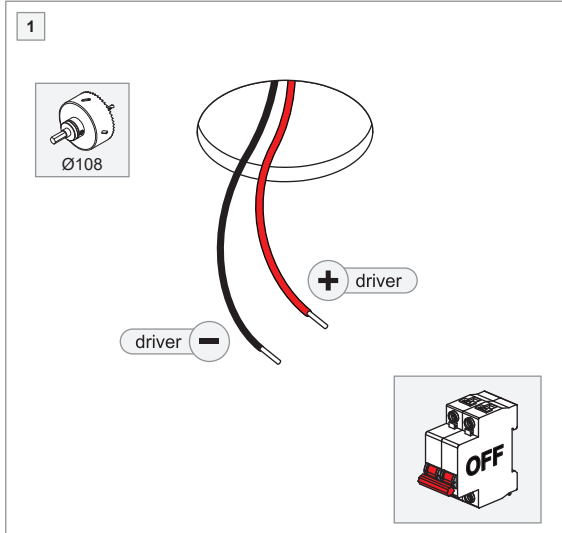
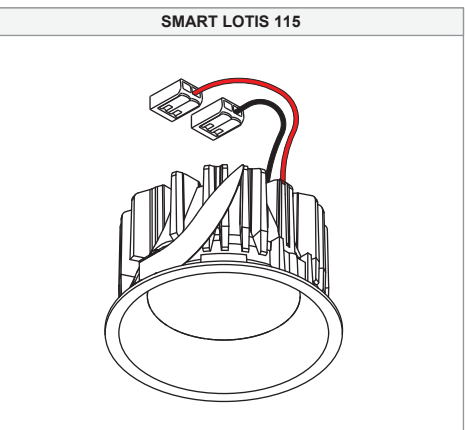
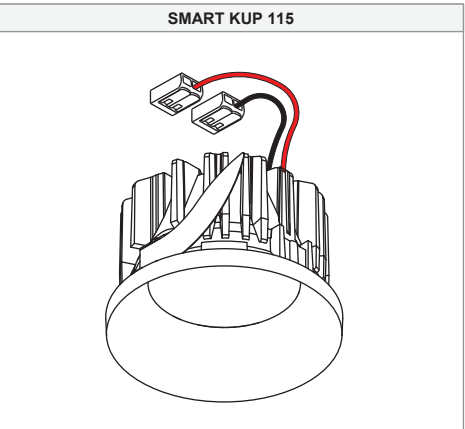
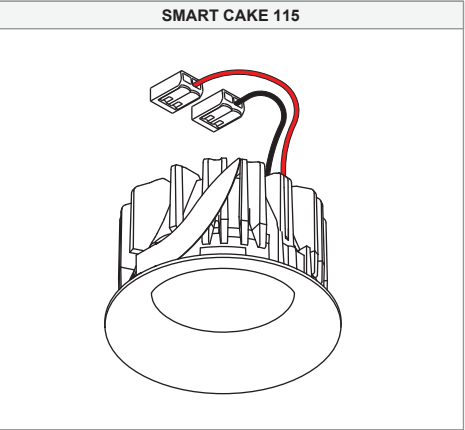

ELECTRICAL SPECS LED-FIXTURE			
Drive Current (mA)	Forward Voltage		Power (W)
	min (Vf)	max (Vf)	
350	28,3	32,9	10,7
500	29,0	33,6	15,7
700	29,7	34,5	22,5

+ RED - BLACK

For serial connection, respect polarity!
Not suited for connection to mains voltage.
Combine with a Modular LED-driver.

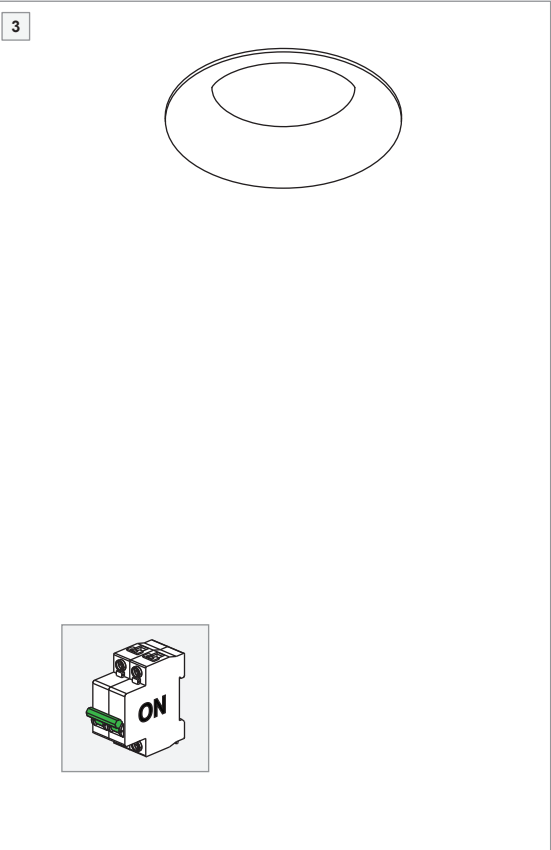
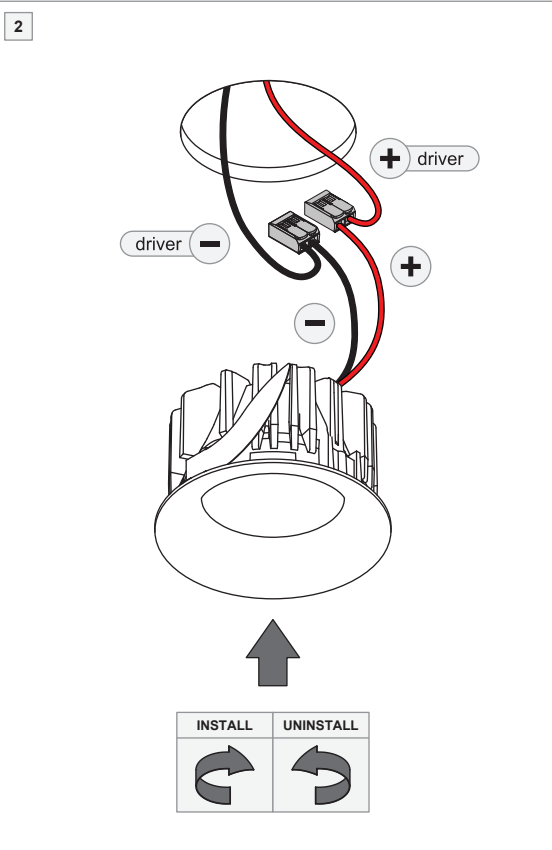
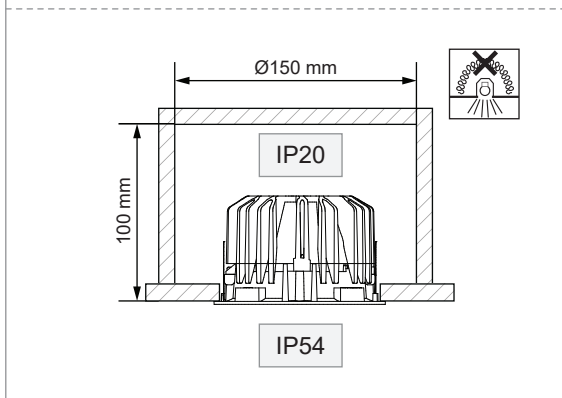

⚠ SERIAL CONNECTION:

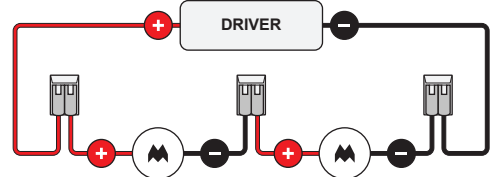

Always use a serial connection for multiple luminaires on a single driver!
Only use luminaires with the same input ratings!

Replace protective shield when broken. The luminaire shall only be used complete with its protective shield. Reference number: 1009392 (clear) or 1009467 (diffuse)

LIGHT SOURCE - DO NOT TOUCH LED
Touching the LED can result in permanent damage of the light source. The light source contained in this luminaire shall only be replaced by the manufacturer or his service agent or a similar qualified person.

PREVENTING ELECTROSTATIC DAMAGE
A discharge of static electricity may damage sensitive components. Always be properly grounded when touching leads or circuitry inside the luminaire. Use a wrist strap connected by a ground cord to the housing. Avoid touching the light sources with bare hands.

DRIVERS & ACCESSORIES
For latest version of driver matrix and available accessories check www.supermodular.com or connect with your sales contact.