

Wink 82 LED GE - Asy Wink 82 LED

14200XXX_B1_14201XXX_B1_14202XXX-B1

Resessed Ring

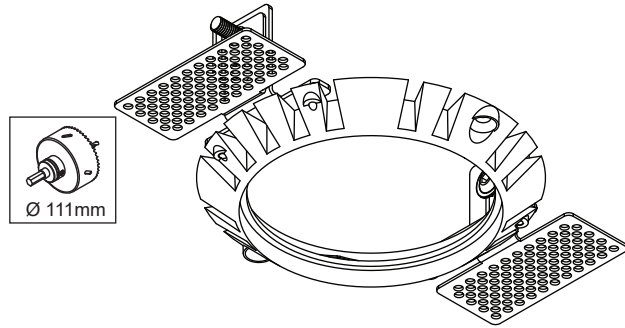

OR

Wink Flange

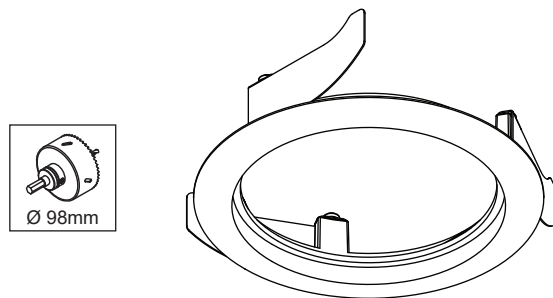

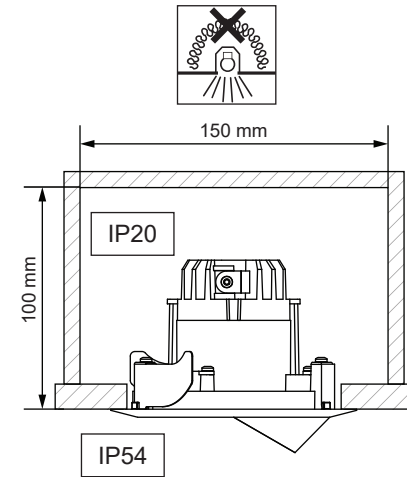
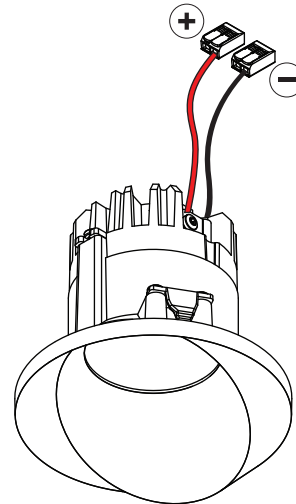

| ELECTRICAL SPECS LED-FIXTURE | | | |
|------------------------------|-----------------|----------|-----------|
| Drive Current (mA) | Forward Voltage | | Power (W) |
| | min (Vf) | max (Vf) | |
| 350 | 13,2 | 15,0 | 5,0 |
| 500 | 13,7 | 15,4 | 7,2 |
| + | | RED | - BLACK |

For serial connection, respect polarity!
Not suited for connection to mains voltage.
Combine with a Modular LED-driver.

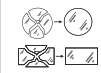

 Replace protective shield when broken. The luminaire shall only be used complete with its protective shield.
Reference number: 1011764 - ASY 1012931

 **LIGHT SOURCE - DO NOT TOUCH LED**
Touching the LED can result in permanent damage of the light source. The light source contained in this luminaire shall only be replaced by the manufacturer or his service agent or a similar qualified person.

 **PREVENTING ELECTROSTATIC DAMAGE**
A discharge of static electricity may damage sensitive components. Always be properly grounded when touching leads or circuitry inside the luminaire. Use a wrist strap connected by a ground cord to the housing. Avoid touching the light sources with bare hands.

DRIVERS & ACCESSORIES
For latest version of driver matrix and available accessories check www.supermodular.com or connect with your sales contact.

