

Track 230V Power Wire Bending Tool

14210000

1 CUT THE TRACK WITH EXACT PERPENDICULAR FINISH

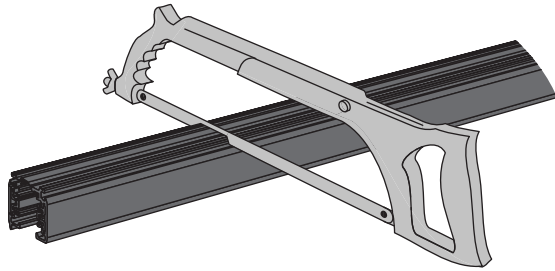

⚠ CUT PERPENDICULAR!

2 INSERT BENDING TOOL AS DEEP AS POSSIBLE TO ENSURE BENDING POINT IS AT THE CORRECT PLACE

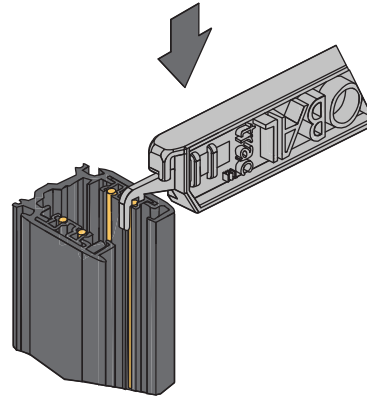

3 BEND THE 4 COPPER WIRES
(for dali tracks: middle dali coppers do not require bending)

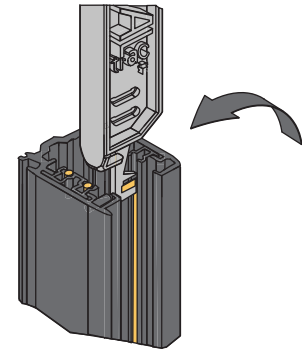

4 INSERT OTHER END OF THE TOOL TO CHECK IF ALL BENDS ARE CORRECT

the tool must fit between the copper ends and the side of the tool must slide to even level with the end surface of the track.

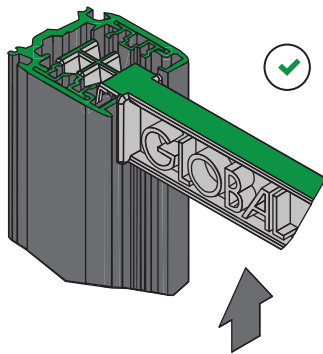

5 COMPLETED AND READY FOR FURTHER INSTALLATION

