

Smart Cake/Kup/Lotis 82 IP LED DE

124120XX_124121XX_124122XX_124123XX_124124XX_124125XX_124126XX_124127XX_124128XX_124420XX_124421XX_124422XX_124423XX_124424XX_124425XX_124426XX_124427XX_124428XX_124720XX_124721XX_124722XX_124723XX_124724XX_124725XX_124726XX_124727XX_124728XX

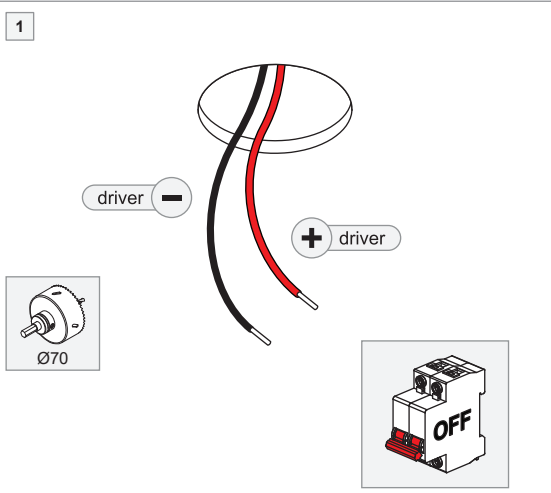
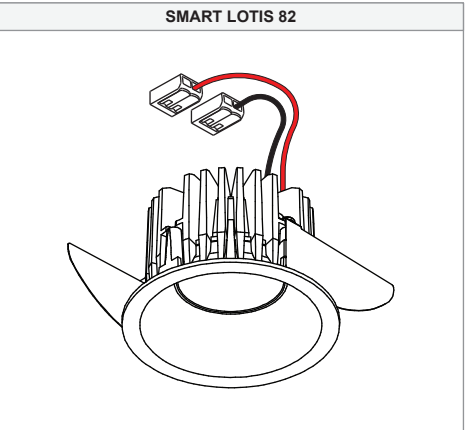
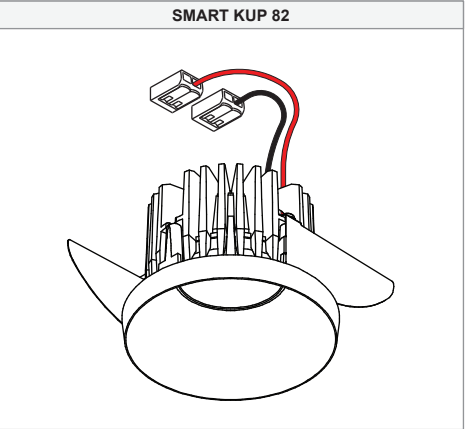
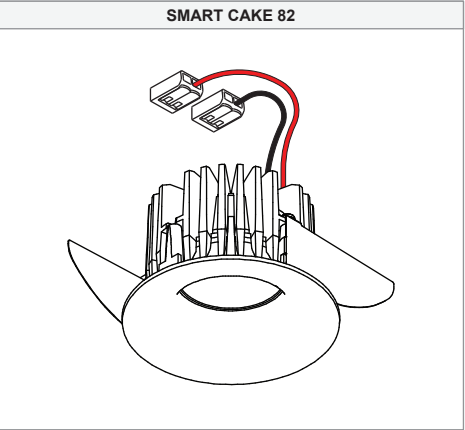

ELECTRICAL SPECS LED-FIXTURE

Drive Current (mA)	Forward Voltage		Power (W)
	min (Vf)	max (Vf)	
350	13,2	15,0	5,0
500	13,7	15,4	7,2
700	14,2	16,0	10,6

+ RED - BLACK

For serial connection, respect polarity!
Not suited for connection to mains voltage.
Combine with a Modular LED-driver.

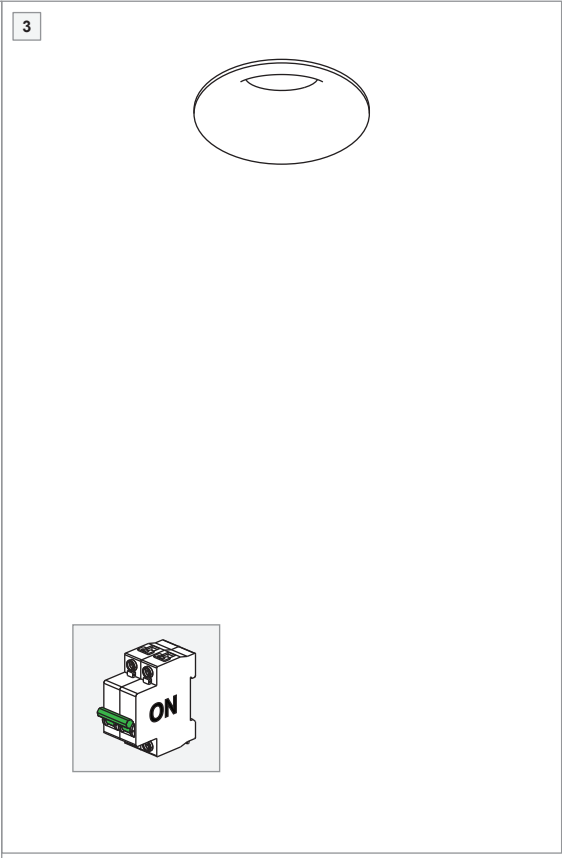
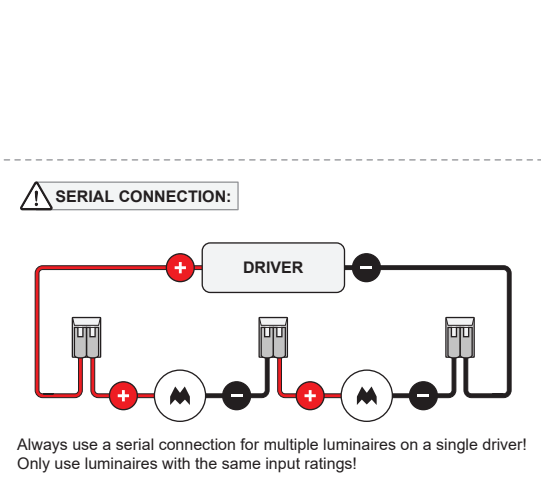
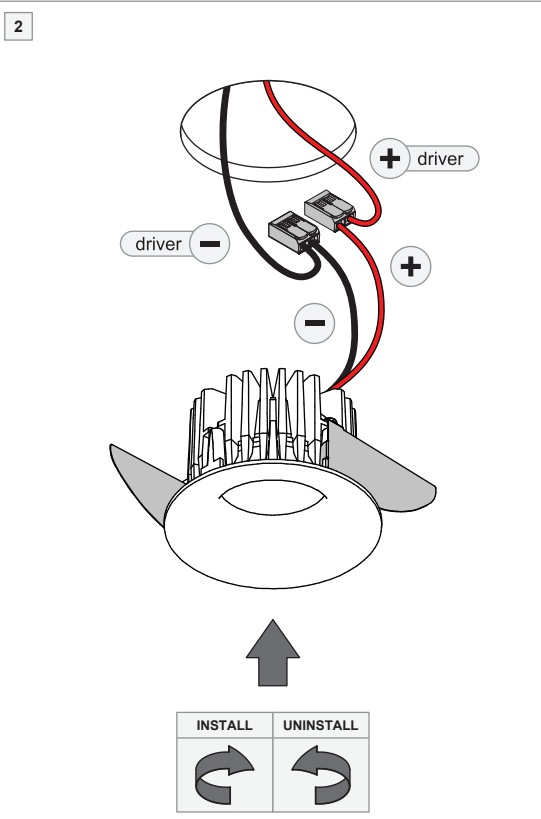
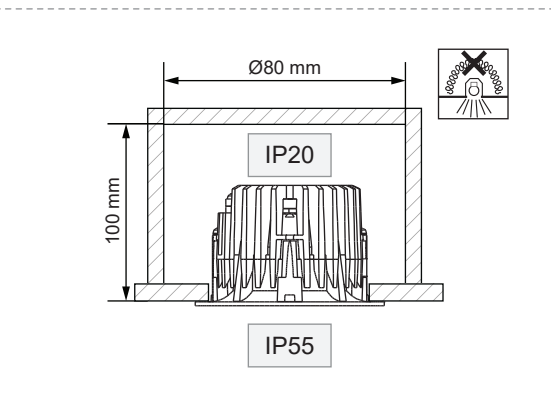

Touching the LED can result in permanent damage of the light source. The light source and/or driver contained in this luminaire shall only be replaced by the manufacturer or his service agent or a similar qualified person.

A discharge of static electricity may damage sensitive components. Therefore do not touch the LED nor the stripped parts of the wires with bare hands. Always be properly insulated by using ESD gloves.

DRIVERS & ACCESSORIES

For latest version of driver matrix and available accessories check www.supermodular.com or connect with your sales contact.