



MODULAR
LIGHTING
INSTRUMENTS
— by MLI NA Corporation

Project

Type

Contact

Qbini Frame Recessed

Overview



Qbini families are tiny, playful and many. Qbini Frame Recessed allows you to play with all of them and hide any imperfections in the ceiling around the lamps. Choose a black or white box that accommodates one or two Qbini lamps, Qbini General, or just a blind plate, and start combining!

Configurations

	A	B		
1 Module	2.53"	2.53"		
2 Module	4.28"	2.53"		
3 Module	6.03"	2.53"		
4 Module	7.78"	2.53"		

How to Specify (Example)

1. Select Frame Configuration → Page 2

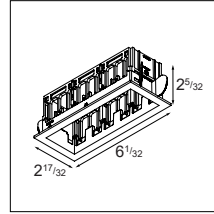

Example: **QBINF-R-3X-BLS**
(3 module trim frame black)

2. Select Each Lamp Module → Page 3 & 4

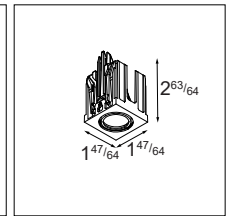
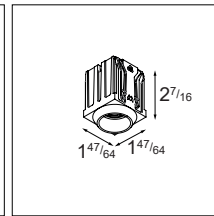
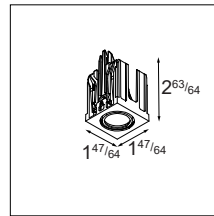

Example: **QBINI-AD-1X-30F-DP-DE-BLS**
QBINI-RT-1X-30F-DP-DE-BLS
QBINI-AD-1X-30F-DP-DE-BLS
(2x Qbini Adj. 3000K, flood, black)
1x Qbini RT. 3000K, flood, black)

3. Select Housing / Driver Type → Pages 5 through 7

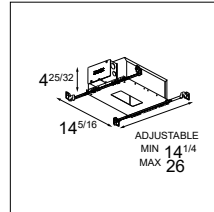

Example: **IC-UAT-QBINI-TF-3X-010P-500**
(IC Housing, 3 module, 0-10V / ELV
1% dimming, 500mA)

4. Select Optional Accessories → Page 8

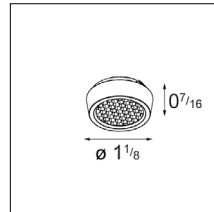

Example: **O-HC-1.0-BL**
(3x Honeycomb, black)

Example Order:

Qty.	Item
1	QBINF-R-3X-BLS
2	QBINI-AD-1X-30F-DP-DE-BLS
1	QBINI-RT-1X-30F-DP-DE-BLS
1	IC-UAT-QBINI-TF-3X-010P-500
3	O-HC-1.0-BL



Frame Specifications & Ordering Information

- Bezel Material: Cast Aluminum
- Retention Frame Material: PBT
- Bezel Finish: Powder Coat or Wet Paint*
- Must be combined with Housing

* Wet Paint is only used for the gold finish

Frame Finish Options

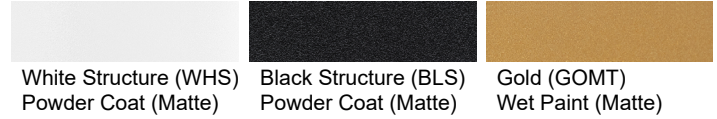

Dual positioning

For each Lamp Module, two positions are possible:

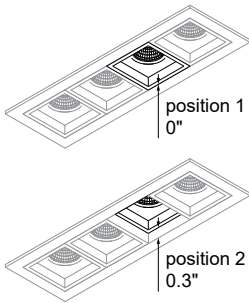

Flange overlap & thickness

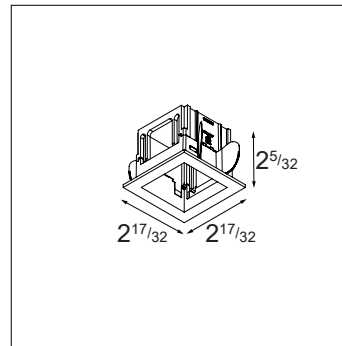
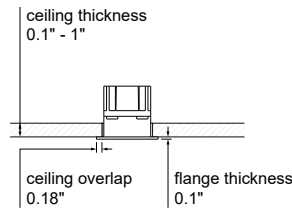

Qbini frame 1X

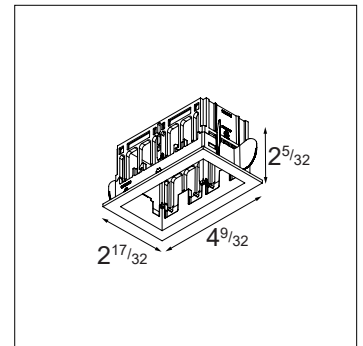

Qbini frame 2X

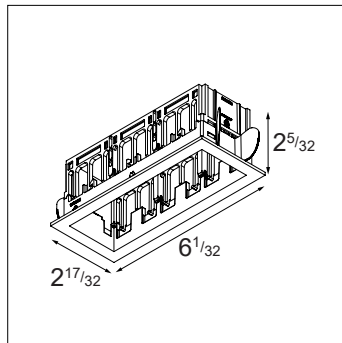

Qbini frame 3X

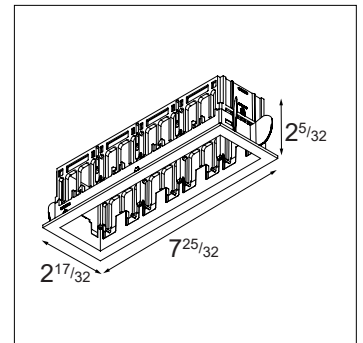

Qbini frame 4X

Ordering Information



QBINF-R	Qbini Frame	1X	1 Module	WHS	White Structure
		2X	2 Module	BLS	Black Structure
		3X	3 Module	GOMT	Gold
		4X	4 Module		

Lamp Specifications & Ordering Information

- Material: Cast Aluminum
- Finish: Powder Coat
- Adjustable: 350° x 30°

* Wet Paint is only used for the gold finish

Lamp Module Finish Options

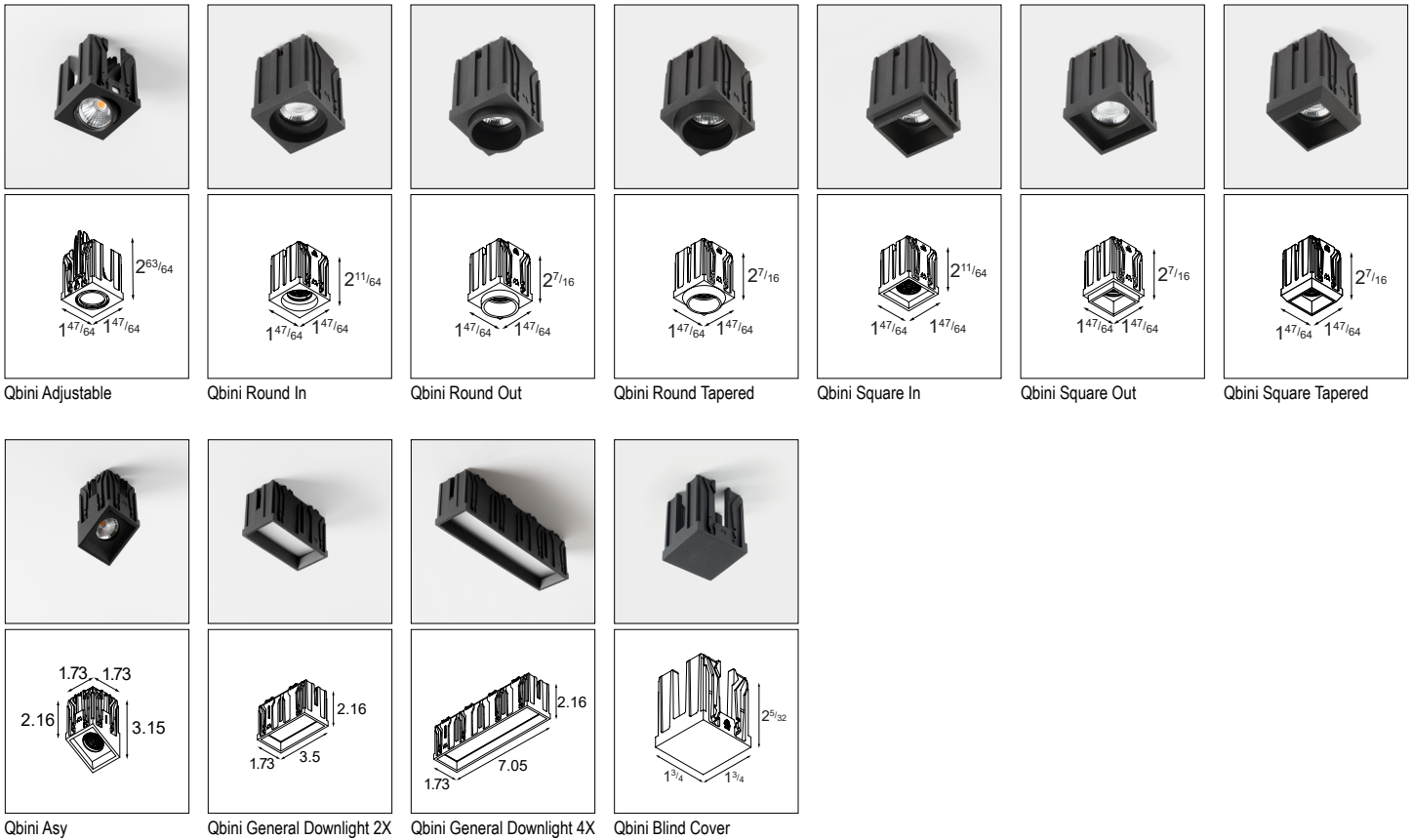
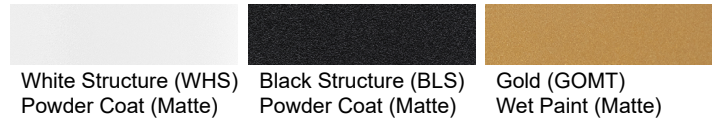

Lamp Specifications & Ordering Information

Ordering Information

QBINI	-	-	-	-	-	DP	-	DE	-
						DP	-	DE	-
						DP	-	DE	-
						DP	-	DE	-

AD-1X Adjustable	blank Clear Glass or frosted PMMA ⁽²⁾	27 2700K	blank not applicable	DP Damp Location	DE Driver Excluded	WHS White Structure
RI-1X Round In	FG Frosted Glass ⁽¹⁾	30 3000K	M Medium (26°)			BLS Black Structure
RO-1X Round Out	MG Microprismatic Glass	35 3500K	F Flood (41°)			GOMT Gold
RT-1X Round Tapered		WD Warm Dim*** 3000K - 1800K	WF Wide Flood (65°) ⁽¹⁾			
SI-1X Square In						
SO-1X Square Out			Warm Dim			
ST-1X Square Tapered			F Flood (37°)			
AY-1X Asy			WF Wide Flood (66°) ⁽¹⁾			
GE-2X General Downlight (2X)*						
GE-4X General Downlight (4X)**						
BC Blind Cover	<i>! not applicable for Blind Cover</i>	<i>! not applicable for Blind Cover</i>	<i>! not applicable for General Downlight & Blind Cover</i>	<i>! not applicable for Blind Cover</i>	<i>! not applicable for Blind Cover</i>	

⁽¹⁾ Wide Flood beam angle only in combination with Frosted Glass
⁽²⁾ Frosted PMMA only applies to General Downlight lamp modules
* General 2X takes up 2 slots in the frame (cannot be combined with 1X frames)
** General 4X takes up 4 slots in the frame (can only be combined with 4X frames)
*** Warm Dim not available for General Downlight

! 1 LAMP MODULE IS NEEDED FOR EACH MODULE QUANTITY DEFINED BY THE FRAME

Housing & Driver Specifications

Driver Integrated Housing Options

- Material: Sheet metal (galvanized steel)
- Driver: Included in Housing
- CCEA Chicago Plenum rated & Airtight per ASTM-E283-04 (when used with IC-UAT box)
- Not compatible with Warm Dim, Qbini Asy, Qbini General 2X, Qbini General 4X or Blind Cover

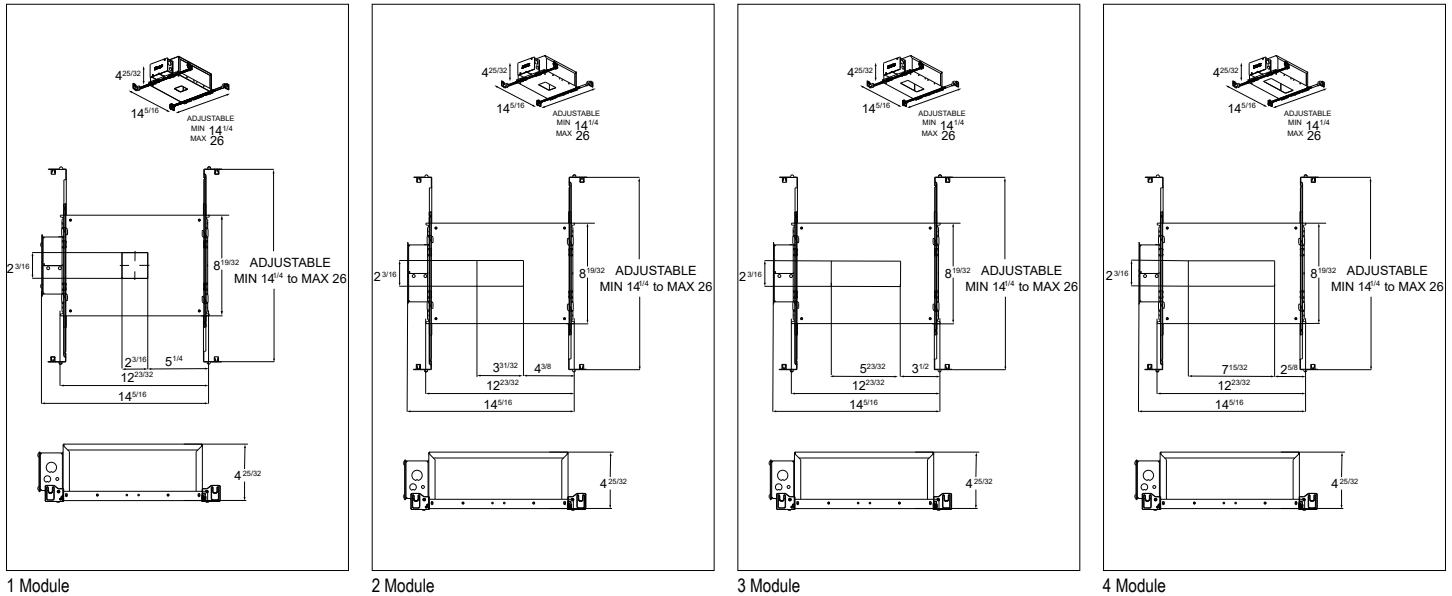

Driver Specifications

DRIVER	OUTPUT CURRENT	INPUT VOLTAGE	DIMMING TYPE	TYPICAL DIMMING LEVEL**	CONNECTED LOAD (TYPICAL)			
					1X	2X	3X	4X
010P-350	350mA	120-277VAC, 120VAC*	0-10V, ELV & Triac	1%		7.5 W	10.9 W	14.2 W
010P-500	500mA	120-277VAC, 120VAC*	0-10V, ELV & Triac	1%	6 W	12 W	16 W	

* Dimming via ELV and Triac only compatible at 120VAC

** Consult the factory for dimmer compatibility

Ordering Information

IC-UAT	QBINI	TF	Module Count	Driver Part Number	Driver Description
IC-UAT Insulation Contact Rated, ultra air-tight		TF Trimmed Flange	1X 1 Module	010P-350 010P-500	0-10V/ELV/Triac 350mA (not available for 1X configuration) 0-10V/ELV/Triac 500mA (not available for 4X configuration)
			2X 2 Module		
			3X 3 Module		
			4X 4 Module		

! # OF MODULE SHOULD MATCH BETWEEN THE TRIMMED FLANGE AND THE HOUSING

Housing & Driver Specifications - cntd.

IC-UAT Housing Options for Remote Driver

- Material: Sheet metal (galvanized steel)
- Driver: Remote. Specify on pages 7 & 8.
- CCEA Chicago Plenum rated & Airtight per ASTM-E283-04
- Built in electrical connection box with 2x 7/8" knockout
- Bar hangers adjustable by 1.5" to accomodate different mounting heights or ceiling thicknesses

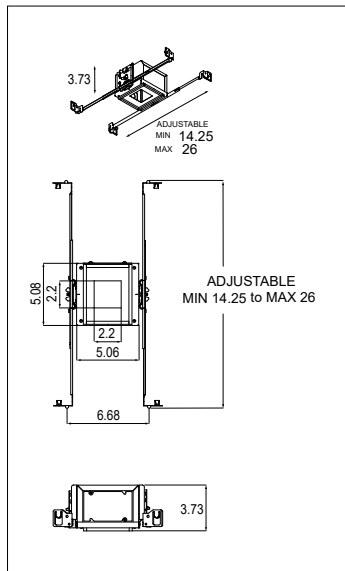

IC-BOX Qbini 1X for remote driver

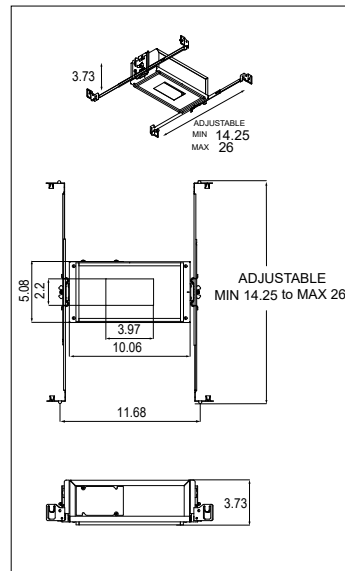

IC-BOX Qbini 2X for remote driver

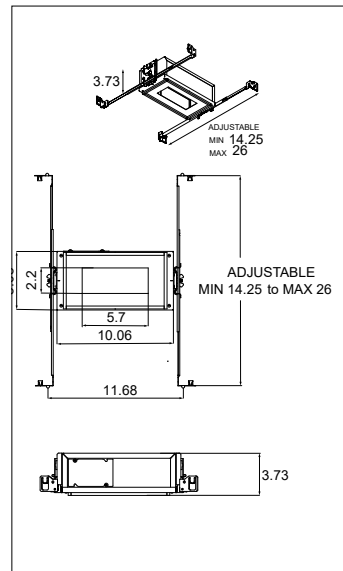

IC-BOX Qbini 3X for remote driver

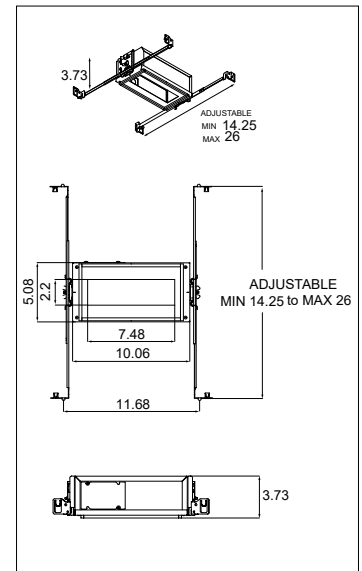

IC-BOX Qbini 4X for remote driver

Ordering Information

SELECTION	ORDERING CODE	FRAME TYPE	# MODULE POSITIONS	MODULE TYPE	COMPATIBLE DRIVE CURRENT*
←	ICB-QBINI-TF-RD-1X-250	Trimmed	1X	Warm Dim	250mA
	ICB-QBINI-TF-RD-1X-500	Trimmed	1X	Fixed CCT	350mA & 500mA
	ICB-QBINI-TF-RD-2X-250	Trimmed	2X	Warm Dim	250mA
	ICB-QBINI-TF-RD-2X-500	Trimmed	2X	Fixed CCT	350mA & 500mA
	ICB-QBINI-TF-RD-3X-500	Trimmed	3X	Fixed CCT	350mA & 500mA
	ICB-QBINI-TF-RD-4X-350	Trimmed	4X	Fixed CCT	350mA

* Drive current of IC Box must match remote driver current selection on Page 8

! # OF MODULE SHOULD MATCH BETWEEN THE TRIMMED FLANGE AND THE HOUSING

Accessories Specifications

- Accessories are optional
- Accessories can installed / changed in the field
- Consult website for photometric performance
- Cannot be used with Qbini General

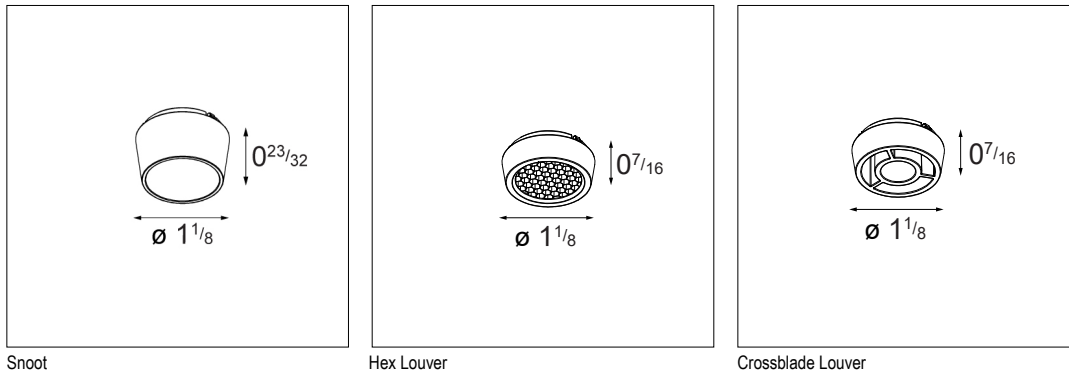

Ordering Information

O	-	-	1.0	-	BLS
		-	1.0	-	BLS

O	Optical	CB	Crossblade	1.0	1.0" Dia.	BLS	Black Structure
		HC	Honeycomb				
		SN	Snoot				

Performance Specifications (per lamp module)

	Single Lamp Units	General 2X	General 4X				
Weight	0.53Xbs	0.8lbs	1.45lbs				
Location	Damp						
CRI*	3000K: 92, R9: 58 Warm Dim: 96, R9: 94						
Lifetime	L80 B20 @ 50.000 hrs						
UGR	see website						
Electrical (typical)							
	Single Lamp Units			General Lamp Units (Fixed CCT)			
	Fixed CCT		Warm Dim	2X		4X	
	350mA	500mA	250mA	350mA	500mA	350mA	500mA
Vf	8.5V	8.8V	17V	12V	12V	24V	24V
Power	3W	4.4W	4.3W	4.2W	6W	8.4W	12W

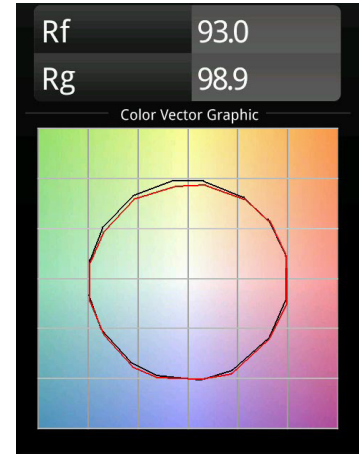
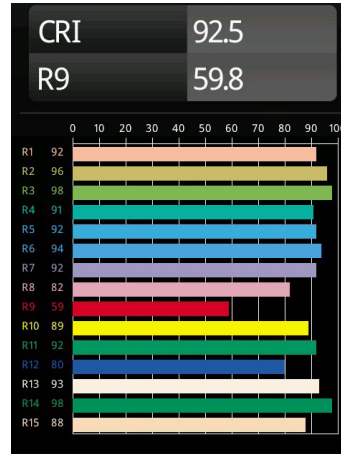

*CRI & TM-30 Value for single lamp unit in 3000K

For photometric files see website or contact factory

Output Specifications

Reference: 3000K, 40deg (FL), 500mA, White
Values below are typical
() indicates multipliers

Shape	Reference Delivered Lumens	CCT	Optics	Current	Finish
Round In	433Xm	2700K (0.96) 3000K (1.0) 3500K (1.1)	FRLWF (0.76) MPLF (0.97) F (1.0) MPLM (0.94) M (0.94)	350mA (0.75) 500mA (1.0)	BLS (0.87) WHS (1.0) GO (0.95)
Round Out	386lm	2700K (0.96) 3000K (1.0) 3500K (1.1)	FRLWF (0.76) MPLF (0.97) F (1.0) MPLM (0.94) M (0.94)	350mA (0.75) 500mA (1.0)	BLS (0.87) WHS (1.0) GO (0.95)
Round Tapered	386lm	2700K (0.96) 3000K (1.0) 3500K (1.1)	FRLWF (0.76) MPLF (0.97) F (1.0) MPLM (0.94) M (0.94)	350mA (0.75) 500mA (1.0)	BLS (0.87) WHS (1.0) GO (0.95)
Square In	422Xm	2700K (0.96) 3000K (1.0) 3500K (1.1)	FRLWF (0.76) MPLF (0.97) F (1.0) MPLM (0.94) M (0.94)	350mA (0.75) 500mA (1.0)	BLS (0.87) WHS (1.0) GO (0.95)
Square Out	390lm	2700K (0.96) 3000K (1.0) 3500K (1.1)	FRLWF (0.76) MPLF (0.97) F (1.0) MPLM (0.94) M (0.94)	350mA (0.75) 500mA (1.0)	BLS (0.87) WHS (1.0) GO (0.95)
Square Tapered	390lm	2700K (0.96) 3000K (1.0) 3500K (1.1)	FRLWF (0.76) MPLF (0.97) F (1.0) MPLM (0.94) M (0.94)	350mA (0.75) 500mA (1.0)	BLS (0.87) WHS (1.0) GO (0.95)
Adjustable	430lm	2700K (0.96) 3000K (1.0) 3500K (1.1)	FRLWF (0.76) MPLF (0.97) F (1.0) MPLM (0.94) M (0.94)	350mA (0.75) 500mA (1.0)	BLS (0.87) WHS (1.0) GO (0.95)
ASY	428lm	2700K (1.0) 3000K (1.0) 3500K (1.0)	FRLWF (0.83) MPLF (1.0) F (1.0) MPLM (0.97) M (0.96)	350mA (0.74) 500mA (1.0)	BLS (0.97) WHS (1.0) GO (0.98)
General 2X	560lm	2700K (1.0) 3000K (1.0) 3500K (1.05)	N/A	350mA (0.72) 500mA (1.0)	BLS (0.84) WHS (1.0) GO (0.91)
General 4X	1247lm	2700K (1.0) 3000K (1.0) 3500K (1.05)	N/A	350mA (0.72) 500mA (1.0)	BLS (0.87) WHS (1.0) GO (0.91)

Example Calculation

To determine typical output for Round In, 2700K, Medium optic, 350mA in Gold:
 $433 \times 0.96 \times 0.94 \times 0.75 \times 0.95 = 278$ lumen

Output Specifications - cntd.

() indicates multipliers

Shape	Reference Delivered Lumens	CCT	Optics	Current	Finish
Round In	330lm	3000K – 1800K (1.0)	FRLWF (0.81) MPLF (0.98) F (1.0)	250mA (1.0)	BLS (0.92) WHS (1.0) GO (0.94)
Round Out	283Xm	3000K – 1800K (1.0)	FRLWF (0.76) MPLF (0.98) F (1.0)	250mA (1.0)	BLS (0.81) WHS (1.0) GO (0.91)
Round Tapered	283Xm	3000K – 1800K (1.0)	FRLWF (0.76) MPLF (0.98) F (1.0)	250mA (1.0)	BLS (0.81) WHS (1.0) GO (0.91)
Square In	332Xm	3000K – 1800K (1.0)	FRLWF (0.81) MPLF (0.98) F (1.0)	250mA (1.0)	BLS (0.92) WHS (1.0) GO (0.96)
Square Out	290lm	3000K – 1800K (1.0)	FRLWF (0.77) MPLF (0.97) F (1.0)	250mA (1.0)	BLS (0.85) WHS (1.0) GO (0.92)
Square Tapered	290lm	3000K – 1800K (1.0)	FRLWF (0.77) MPLF (0.97) F (1.0)	250mA (1.0)	BLS (0.85) WHS (1.0) GO (0.92)
Adjustable	330lm	3000K – 1800K (1.0)	FRLWF (0.91) MPLF (0.99) F (1.0)	250mA (1.0)	BLS (0.91) WHS (1.0) GO (0.96)
ASY	251Xm	3000K – 1800K (1.0)	FRLWF (0.84) MPLF (1.0) F (1.0)	250mA (1.0)	BLS (0.96) WHS (1.0) GO (1.0)

Listings and Certifications

- Damp location listed
- cUL & UL listed
- CCEA Chicago Plenum rated & Airtight per ASTM-E283-04 (when used with IC-UAT housings)

Warranty

Visit <https://www.supermodular.com/warranty>