

Pista Suspended Up/Down Track

Overview

Pista is the ultimate in modern aesthetics, introducing thinner, slimmer magnetic track rails, even smaller light fixtures and ultra-thin cables. But Pista isn't just about miniaturization, it's also about personalization. Designers can create unique configurations and play with different modules on single or multiple track rails in different lengths, light effects and colors.

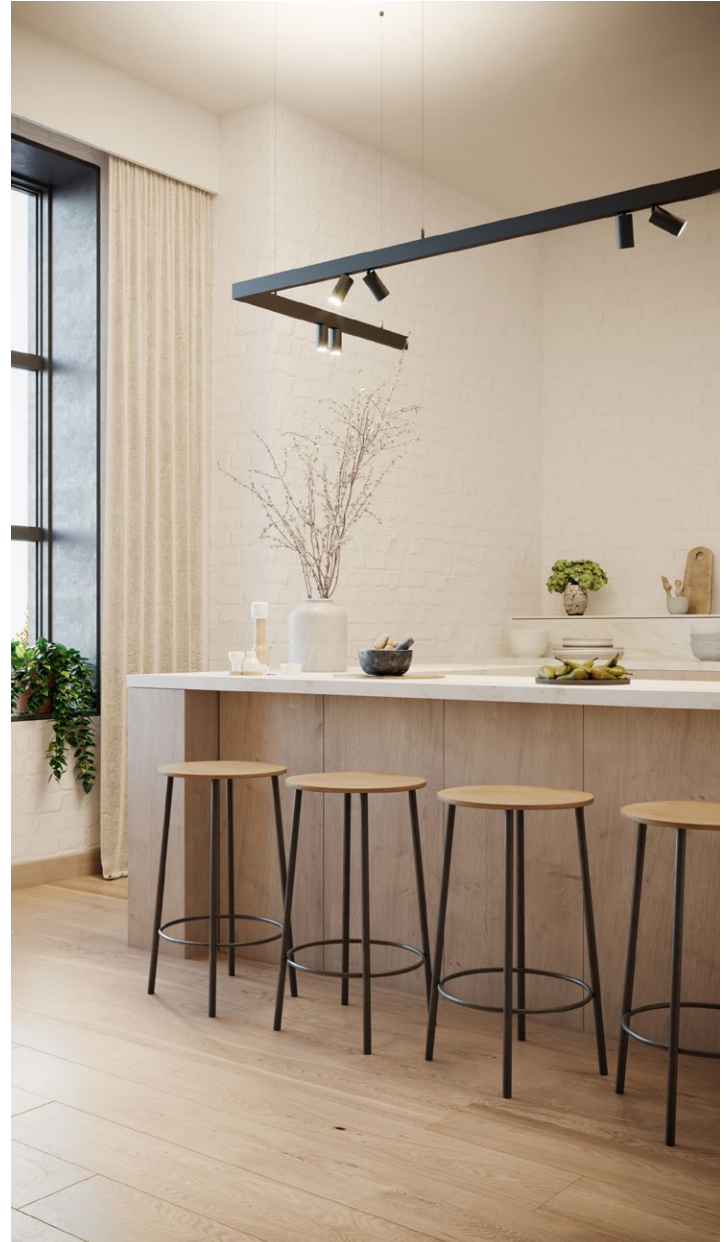

Pista Suspended Up/Down Track

Track Specifications & Ordering Information

General

- Fixtures attach magnetically to the track
- Profile Finish: powder coat
- Can be field cut
- Weight: 0.9lbs per foot
- Dry locations only

Electrical

- cUL Class II only
- 48V DC (see power supply section)
- Circuits: Upper side: 1 circuit + Data bus, lower side: 1 circuit + Data bus
- Upper and lower circuits can be electrically connected using power feeds
- Maximum 100W per track circuit
- Dimming: 0-10V or DALI (specified separately in the fixture)

Finish Information

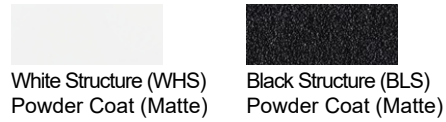

Minimum Suspension Fixation

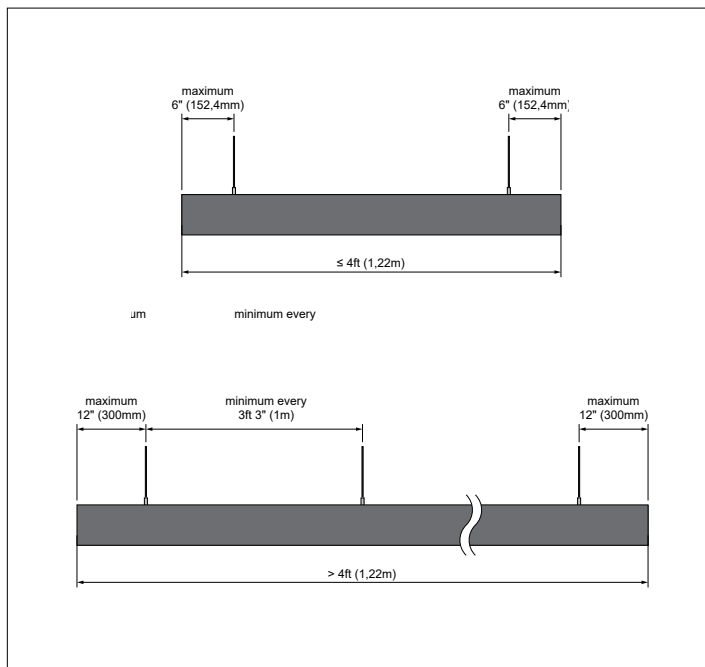

Materials Dimensions & Electrical

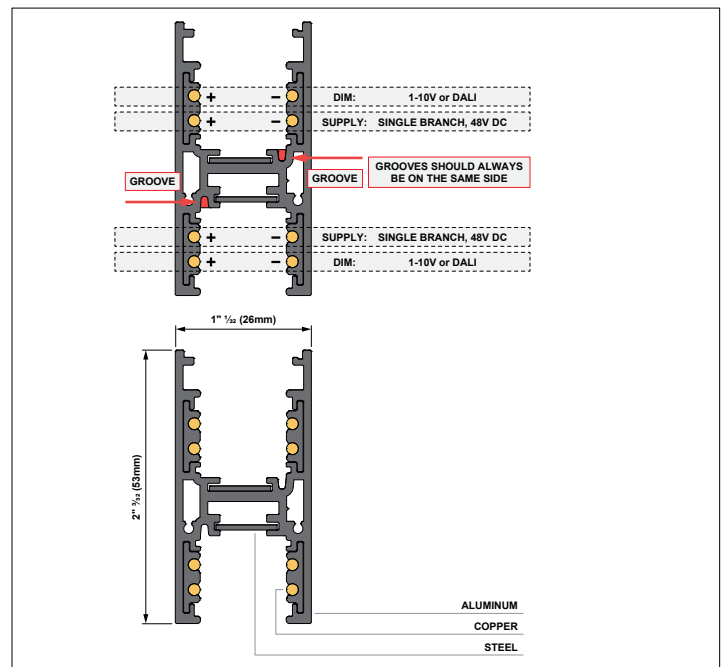

Ordering Information

PISTA-T48V-PROF	-	UD	-	DY	-
		UD Up/Down	<p>39.4 39.4" long (1m)</p> <p>78.7 78.7" long (2m)</p> <p>118.1 118.1" long (3m)</p>	DY Dry Location	<p>WHS White Structure</p> <p>BLS Black Structure</p>

Pista Suspended Up/Down Track

Power Supply Specifications & Ordering Information

REMOTE POWER SUPPLIES

- Must be used with power feed cable + connection box (page 4)
- For cabinet and surface mount use only.
- 4 mounting holes for surface mounting
- 4 knockout holes for low voltage wiring and 4 knockout holes for high voltage wiring
- May be placed up to 50ft away from track using 16AWG wire
- Maximum load: 90% of rated power
- Dry rated
- Weight: 1.4lbs

Ordering Information

SELECTION	ORDERING CODE	POWER	INPUT VOLTAGE	OUTPUT VOLTAGE
	PISTA-T48V-LEDPWRSUPPLY-60W-DY	60W	120 & 277VAC	48VDC
	PISTA-T48V-LEDPWRSUPPLY-96W-DY	96W	120 & 277VAC	48VDC

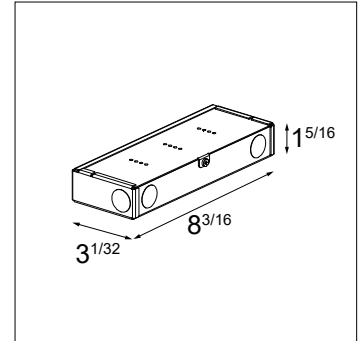

SURFACE MOUNTED POWER SUPPLIES FOR SUSPENDED TRACK

- Included: Plaster finish plate for 4x4 octagonal junction box (cover plates optional)
- Box Material: Cast Aluminum
- Cable finish: PVC
- Cable color: black
- Cable diameter: 0.27"
- Cable length: 78.7"
- Cable length can be field adjusted
- Conductors: 4x 18AWG
- Maximum load: 90% of rated power
- Dry rated
- Weight: 2.2lbs

Ordering Information

PISTA-T48V-SMLEDPWRSUPPLY	SS	DY
40W	SS For Suspended Track	DY Dry Location
60W		
96W		

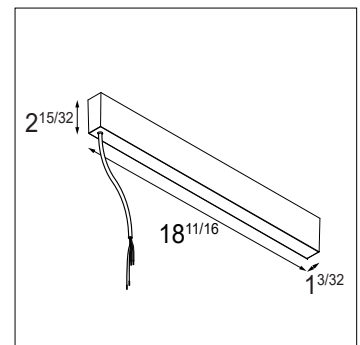

Finish Information



WHS White Structure
BLS Black Structure

Power Supply Specifications & Ordering Information - cntd.

POWER FEED CABLE + CONNECTION BOX

- Only used with remote power supply (page 3)
- Included: Plaster finish plate for 4x4 octagonal junction box (cover plates optional)
- Box Material: Cast Aluminum
- Cable finish: PVC
- Cable color: black
- Cable diameter: 0.27"
- Cable length: 78.7"
- Cable length can be field adjusted
- Conductors: 4x 18AWG
- Dry rated
- Weight: 0.5lbs

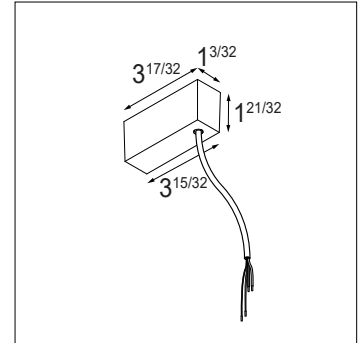

Finish Information



Ordering Information

SELECTION	ORDERING CODE	ITEM	COLOR
	PISTA-T48V-PFC-CONNBOX-DY-WHS	Power Feed Cable + Connection Box	White Structure
	PISTA-T48V-PFC-CONNBOX-DY-BLS	Power Feed Cable + Connection Box	Black Structure

OPTIONAL BACKPLATES

- Accessories are optional (plaster plate comes standard)
- Backplate / Cover Plate provides a cUL listed option for covering a 4x4 octagonal or 3x2 electrical box
- Cover Plate Material: Stainless steel
- Cover Plate Finish: Powder Coat
- Plate Thickness: 0.08"
- Weight: 0.5lbs (for Connection Box)
- Weight: 2.0lbs (for Surface Mounted Power Supply)

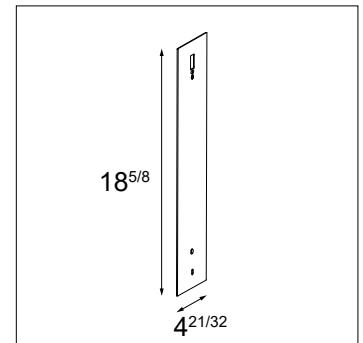

For Surface Mounted Power Supply

Ordering Information

PISTA-T48V-BP-C				
32	For 3"x2" junction box	CB	For use with the power feed cable + connection box	WHS White Structure
44	For 4"x4" junction box	SMGB	For use with the surface mounted power supply	BLS Black Structure

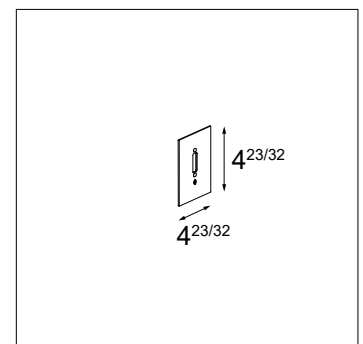

For Power Feed Cable + Connection Box

Finish Information

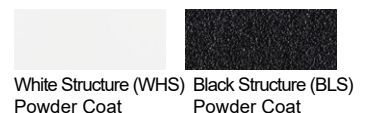

Pista Suspended Up/Down Track

Connectors, Installation Components & Accessories

POWER FEEDS

- “Groove” side is the difference between left and right
- Left vs. Right does not matter if in the middle of the track
- For use with 16-18AWG wire
- Weight: 0.1lbs

Ordering Information

SELECTION	ORDERING CODE	DIRECTION	COLOR
	PISTA-T48V-PFLEFT-DY-WHS	Left	White
	PISTA-T48V-PFLEFT-DY-BLS	Left	Black
	PISTA-T48V-PFRIGHT-DY-WHS	Right	White
	PISTA-T48V-PFRIGHT-DY-BLS	Right	Black

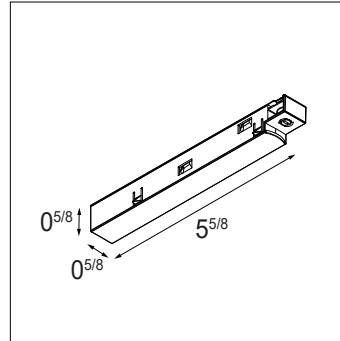

Power feed left

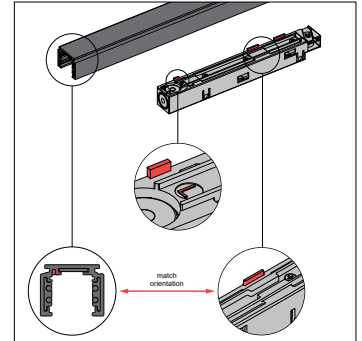

Power feed left - Groove orientation

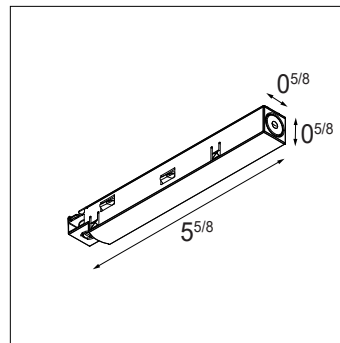

Power feed right

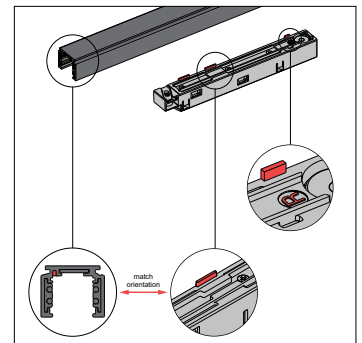

Power feed right - Groove orientation

Pista Suspended Up/Down Track

Connectors, Installation Components & Accessories - contd.

SUSPENDED TRACK CONNECTORS & ACCESSORIES

180 Deg Connector

- Weight: 0.1lbs

Flexible Connector

- Cable diameter: 0.27"
- Cable color: black
- Cable length can be field adjusted
- Weight: 0.5lbs

90 Deg Connector

- Weight: 0.3lbs

Suspension Cable

- Cable color: black
- Cable Diameter: 0.03"
- Cable length can be field adjusted
- Weight: 0.07lbs

Up/Down Suspended Endplates

- Set of 2
- Non-conductive
- Weight: 0.04lbs

Ordering Information

SELECTION	ORDERING CODE	ITEM	COLOR
	PISTA-T48V-CONN180-UD-DY-WHS	180 Deg Up/Down Connector	White
	PISTA-T48V-CONN180-UD-DY-BLS	180 Deg Up/Down Connector	Black
	PISTA-T48V-CONNFLEX-DY-WHS	Flexible Connector	White
	PISTA-T48V-CONNFLEX-DY-BLS	Flexible Connector	Black
	PISTA-T48V-CONN90-UD-DY-WHS	90 Deg Up/Down Connector	White
	PISTA-T48V-CONN90-UD-DY-BLS	90 Deg Up/Down Connector	Black
	PISTA-T48V-CABLE-UD-SS-DY-WHS	Suspension Cable	White
	PISTA-T48V-CABLE-UD-SS-DY-BLS	Suspension Cable	Black
	PISTA-T48V-ENDPLATE-UD-DY-WHS	Up/Down Endplate	White
	PISTA-T48V-ENDPLATE-UD-DY-BLS	Up/Down Endplate	Black

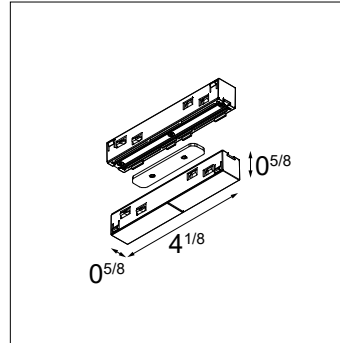

180 Deg Connector

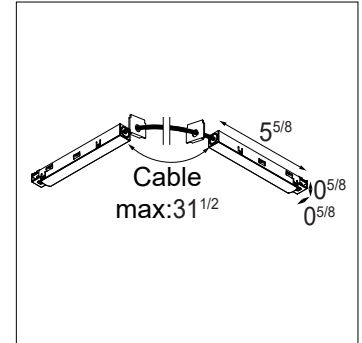

Flexible Connector

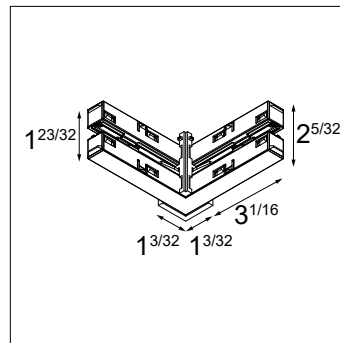

90 Deg Connector

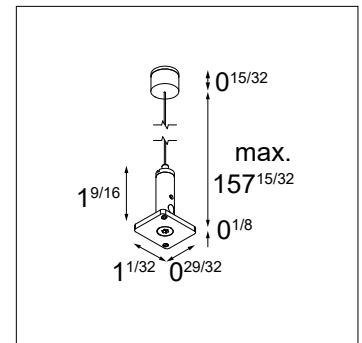

Suspension Cable

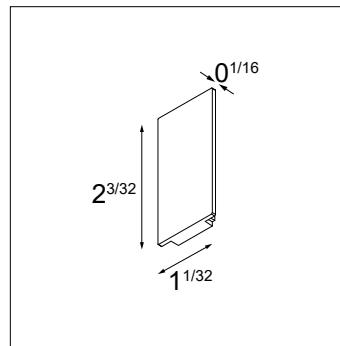

Up/Down Suspended Endplates

Pista Suspended Up/Down Track

Connectors, Installation Components & Accessories - contd.

FINISHING ACCESSORIES

Finishing Cover (optional)

- Can be field cut
- Non-conductive
- Weight: 0.2lbs (39.4" version)
- Weight: 0.4lbs (78.7" version)

Ordering Information

PISTA-T48V-COVER	-	DY	-
39.4	39.4" long (1m)	DY	Dry Location
78.7	78.7" long (2m)		
		WHS	White Structure
		BLS	Black Structure

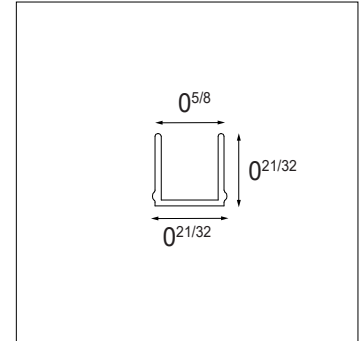

Finishing Cover

Control Accessories

CASAMBI WIRELESS CONTROL

Casambi Track 48V Dim Module

- Utilizes Bluetooth Low Energy Wireless Mesh (no control wires required)
- For individual / discrete fixture control (requires Pista fixtures to be DALI dimmable)
- Connect up to 64 DALI track 48V fixtures to one dim module
- Not to be connected to an existing DALI network; only use as independent system
- Contact customer service for the latest configuration & setup documentation
- Weight: 0.1lbs (39.4" version)

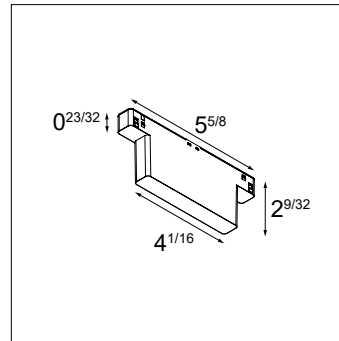

Casambi Track 48V Dim Module



Casambi Track 48V Dim Module

Casambi Wireless Switch

- Range: up to 164 ft in open air
- Weight: 0.2lbs

Ordering Information

SELECTION	ORDERING CODE	ITEM	COLOR
	PISTA-T48V-CASAMBI-DIM-WHS	48 Pista Control Module	White
	PISTA-T48V-CASAMBI-DIM-BLS	48 Pista Control Module	Black
	PISTA-T48V-CASAMBI-SWITCH-WHS	Wireless Switch	White

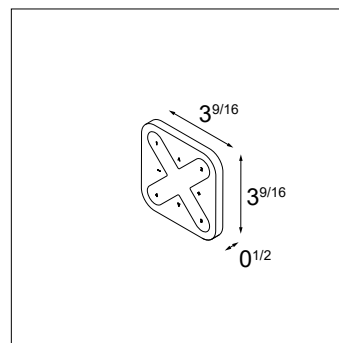

Casambi Wireless Switch



Casambi Wireless Switch

Listings and Certifications

- Dry location listed
- cUL & UL listed

Warranty

Visit <https://www.supermodular.com/warranty>