

## Smart Cake Tube Surface 4.5

### Overview



Smart Cake is part of the Smart family. This family's styling is based on our most popular iconic designs. Its gently sloping sides ensure a soft distribution of light.

With an outer diameter of 4.5" and an aperture of 4.5 inches (fixed version) or 3.3 inches (adjustable version), the Smart Cake 4.5 is compact yet powerful. Combined with a tube (cylinder) that is offered in multiple finishes, the beautiful combinations are yours to discover.

### How to Specify (Example)

#### 1. Select Lamp Module → Page 2

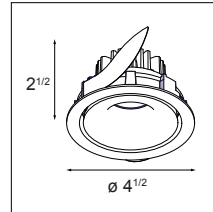

Example: **SMART-C-R-A-4.5-1X-30F-DP-DE-WHS**  
(Smart Cake Recessed Adjustable 4.5 1x, 3000K, flood, damp rated, driver excluded, white structure)

#### 2. Select Tube Body & Driver → Page 3

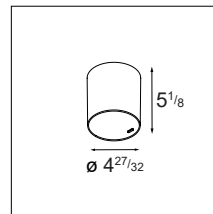

Example: **SMARU-S-4.5-1X-DP-010P-DI-500-WHS**  
(Smart Tube Surface 4.5, 1 lamp, damp rated, 0-10V/ELV, driver included, 500mA, white structure)

#### Example Order:

| Qty. | Item                              |
|------|-----------------------------------|
| 1    | SMART-C-R-A-4.5-1X-30F-DP-DE-WHS  |
| 1    | SMARU-S-4.5-1X-DP-010P-DI-500-WHS |

## Lamp Specifications & Ordering Information

- Aperture: 4.5" (fixed version) / 3.3" (adjustable version)
- Adjustability: 0-25° (adjustable version only)
- Trim Material: Cast Aluminum
- Trim Finish: Powder Coat or Wet Paint\*
- Must be combined with tube

\* Wet Paint is only used for the gold finish

### Lamp Module Finish Options

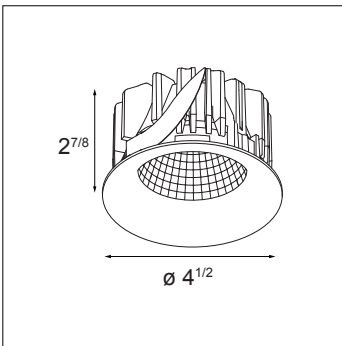
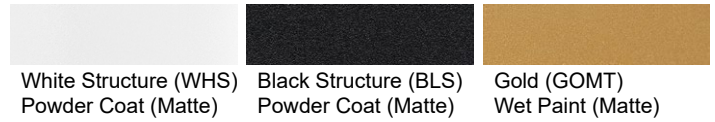

Smart Cake Recessed 4.5

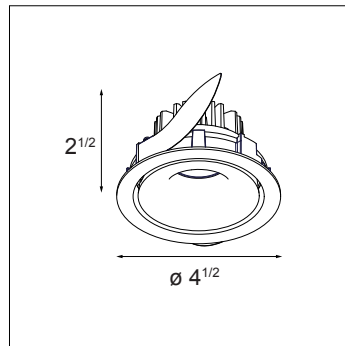

Smart Cake Recessed Adjustable 4.5

## Ordering Information

| SMART-C-R-4.5-1X           |  |                 |   | DP                      |                           | DE                         |  |
|----------------------------|--|-----------------|---|-------------------------|---------------------------|----------------------------|--|
| Smart Cake Recessed 4.5 1x | <b>[blank]</b> No Glass <sup>(1)</sup>         | <b>27</b> 2700K | <b>S</b> Spot 13° <sup>(1)</sup>  | <b>DP</b> Damp Location | <b>DE</b> Driver Excluded | <b>WHS</b> White Structure |  |
|                            | <b>MPG</b> Microprismatic Glass <sup>(2)</sup> | <b>30</b> 3000K | <b>M</b> Medium 25° <sup>(1)/(2)</sup>                                    |                         |                           | <b>BLS</b> Black Structure |  |
|                            | <b>FRG</b> Frosted Glass <sup>(3)</sup>        | <b>35</b> 3500K | <b>F</b> Flood 39° <sup>(1)</sup> /41° <sup>(2)</sup> /37° <sup>(3)</sup> |                         |                           | <b>GOMT</b> Gold Matt      |  |

| SMART-C-R-A-4.5-1X                    |                 |                     |                         | DP                        |                            | DE |  |
|---------------------------------------|-----------------|---------------------|-------------------------|---------------------------|----------------------------|----|--|
| Smart Cake Recessed Adjustable 4.5 1x | <b>27</b> 2700K | <b>S</b> Spot 13°   | <b>DP</b> Damp Location | <b>DE</b> Driver Excluded | <b>WHS</b> White Structure |    |  |
|                                       | <b>30</b> 3000K | <b>M</b> Medium 25° |                         |                           | <b>BLS</b> Black Structure |    |  |
|                                       | <b>35</b> 3500K | <b>F</b> Flood 39°  |                         |                           | <b>GOMT</b> Gold Matt      |    |  |

### Tube & Driver Specifications

- Tube Material: Cast Aluminum
- Driver: Included in tube
- Designed to install to a 4x4 octagonal junction box
- Weight: 2.4lbs

### Tube Finish Options

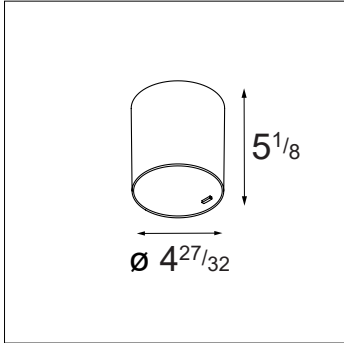
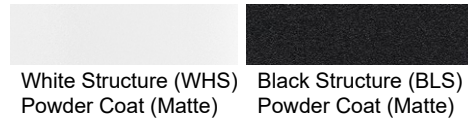

Smart Tube Surface 4.5

### Driver Specifications

| DRIVER   | OUTPUT CURRENT | INPUT VOLTAGE       | DIMMING TYPE       | TYPICAL DIMMING LEVEL** | CONNECTED LOAD (TYPICAL) |            |
|----------|----------------|---------------------|--------------------|-------------------------|--------------------------|------------|
|          |                |                     |                    |                         | FIXED                    | ADJUSTABLE |
| 010P-500 | 500mA          | 120-277VAC, 120VAC* | 0-10V, ELV & Triac | 1%                      | 19.1 W                   | 10.5 W     |

\* Dimming via ELV and Triac only compatible at 120VAC

\*\* Consult the factory for dimmer compatibility

### Tube Ordering Information

|                         |   | DP                   | 010P                        | DI                        | 500              |                            |  |
|-------------------------|---|----------------------|-----------------------------|---------------------------|------------------|----------------------------|--|
| <b>SMARU-S-4.5-1X</b>   | Smart Tube Surface 4.5, 1 lamp            | <b>DP</b> Damp Rated | <b>010P</b> 0-10V/ELV/Triac | <b>DI</b> Driver Included | <b>500</b> 500mA | <b>WHS</b> White Structure |  |
| <b>SMARU-S-A-4.5-1X</b> | Smart Tube Surface Adjustable 4.5, 1 lamp |                      |                             |                           |                  | <b>BLS</b> Black Structure |  |

## Performance Specifications (per lamp)

|                      | Fixed                | Adjustable |
|----------------------|----------------------|------------|
| Weight               | 1.3lbs               | 1.0lbs     |
| Adjustability        | -                    | 0-25°      |
| CRI*                 | 92, R9: 71           |            |
| Location             | Damp                 |            |
| Lifetime             | L80 B20 @ 50.000 hrs |            |
| UGR                  | see website          |            |
| Electrical (typical) |                      |            |
|                      | Fixed                | Adjustable |
|                      | 500mA                | 500mA      |
| Vf                   | 31.3V                | 14.4V      |
| Power                | 15.7W                | 7.2W       |

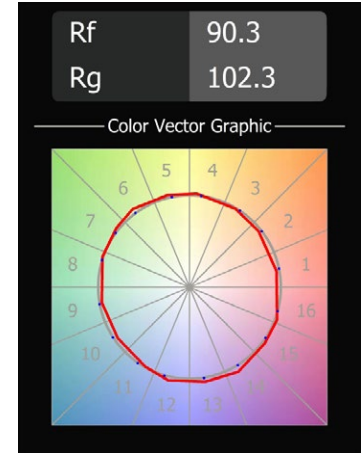
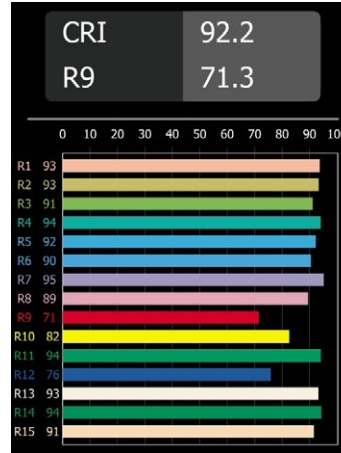

\*CRI & TM-30 Value for 3000K, Fixed

For photometric files see website or contact factory

## Output Specifications

Reference: 3000K, 40deg (FL), 500mA, White  
Values below are typical  
( ) indicates multipliers

### Fixed Lamp

| Reference Delivered Lumens | CCT   | Optics   | Current     | Finish                                 |
|----------------------------|---|--|-------------|--|
| 1590                       | 2700K (0.95)<br>3000K (1.0)<br>3500K (1.07) | S (1.05)<br>M (1.02)<br>F (1.0)<br>MPG M (1.03)<br>MPG F (1.0)<br>FRG F (0.92) | 500mA (1.0) | WHS (1.0)<br>GOMT (0.93)<br>BLS (0.89) |

### Adjustable Lamp

| Reference Delivered Lumens | CCT   | Optics                          | Current     | Finish                                 |
|----------------------------|---|---------------------------------|-------------|--|
| 618                        | 2700K (0.96)<br>3000K (1.0)<br>3500K (1.04) | S (1.13)<br>M (1.06)<br>F (1.0) | 500mA (1.0) | WHS (1.0)<br>GOMT (0.91)<br>BLS (0.75) |

### Example Calculation

To determine typical output for 2700K, Medium optic, 500mA in Gold:  
 $618 \times 0.96 \times 1.06 \times 1.0 \times 0.91 = 572 \text{ lumen}$

## Listings and Certifications

- Damp location listed
- cUL & UL listed

## Warranty

Visit <https://www.supermodular.com/warranty>