

# Pista surface mounted LED power supply 48V (for suspended installation)

US\_134121XX\_US\_134123XX\_US\_134185XX

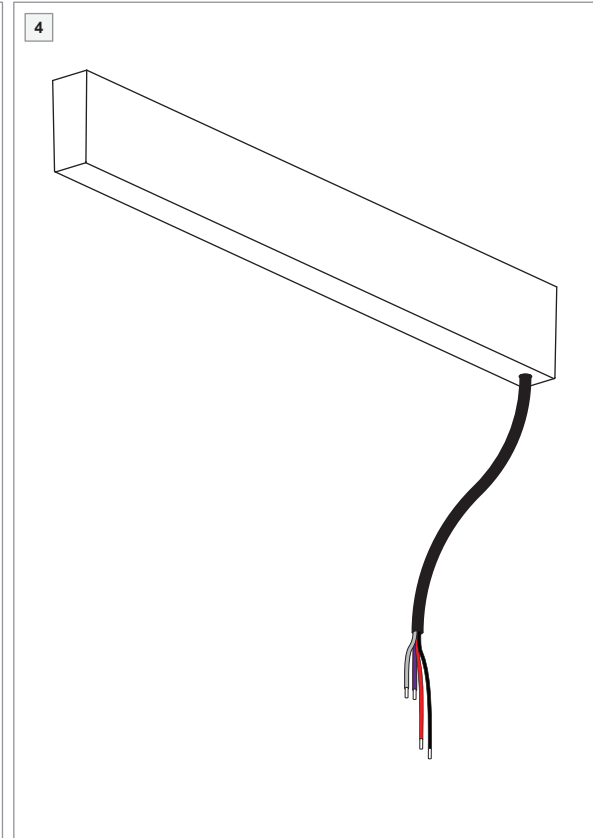
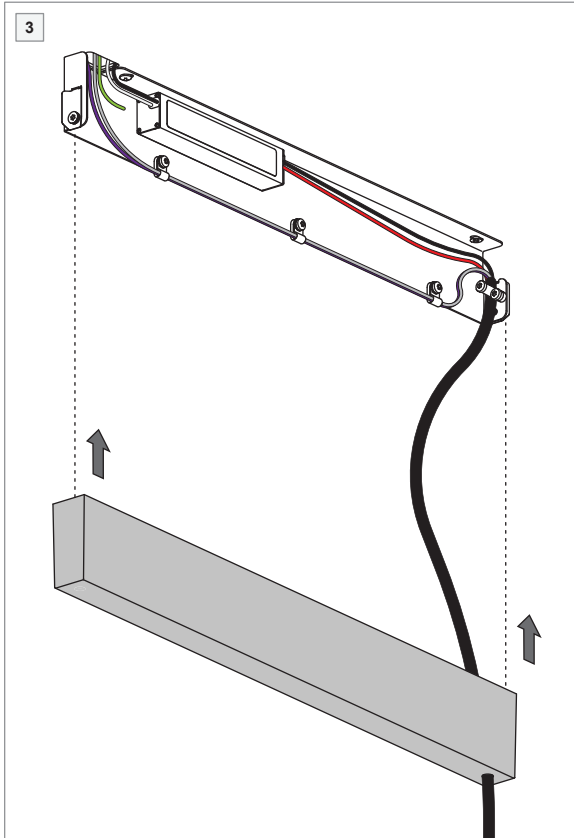
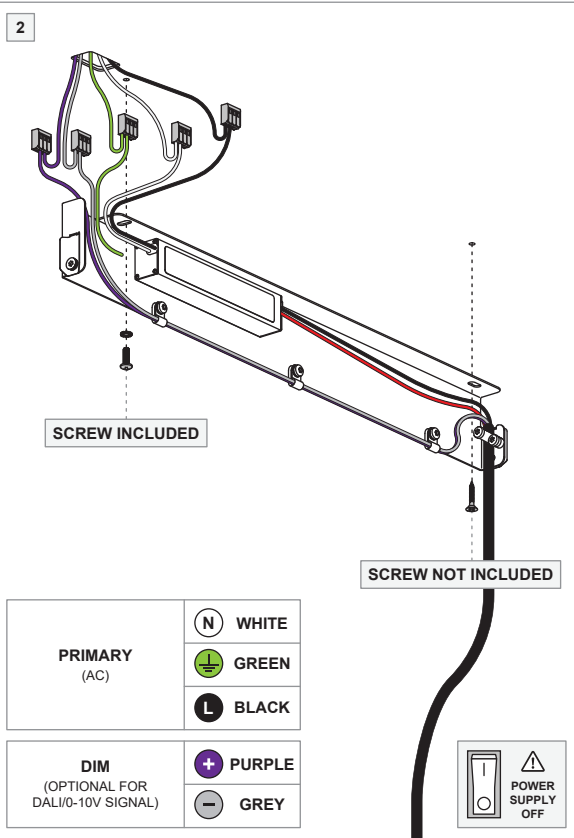
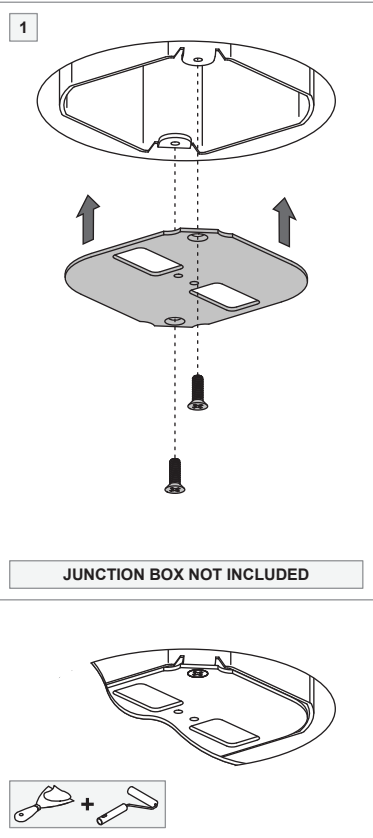

## ELECTRICAL RATINGS

VERSION	INPUT		OUTPUT	
	Voltage (V)	Frequency (Hz)	Voltage (V)	Power (W)
US_134121XX (40W)	120 - 277 AC	50 - 60	48 DC	40
US_134123XX (60W)				60
US_134185XX (96W)				96

## MOUNTING HOLES

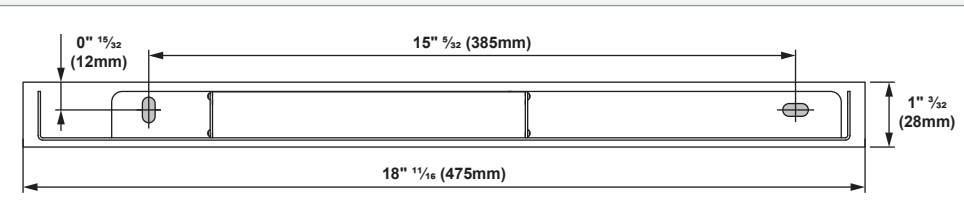

## SECONDARY ELECTRICAL CONNECTION WITH PISTA POWER FEED

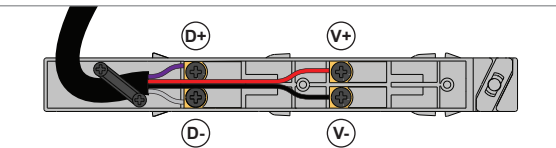
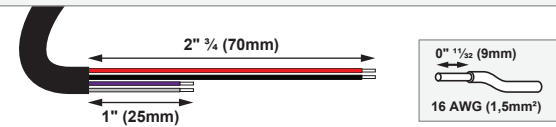

SECONDARY (DC)	V+	RED	DIM (OPTIONAL FOR DALI/0-10V SIGNAL)	D+	PURPLE
	V-	BLACK		D-	GREY

## LOW VOLTAGE LUMINAIRE POWER SUPPLY

### IMPORTANT SAFETY INSTRUCTIONS

- Read all instructions.
- Save these instructions.

### BASIC SAFETY PRECAUTIONS

- Suitable for damp locations.
- Min. 90°C supply conductors.



### PREVENTING ELECTROSTATIC DAMAGE

A discharge of static electricity may damage sensitive components. Always be properly grounded when touching leads or circuitry inside the luminaire. Use a wrist strap connected by a ground cord to the housing. Avoid touching the light sources with bare hands.

### CAN BE COMBINED WITH

- Pista power feed (1x)

### LIGHT ENGINES & ACCESSORIES

For latest version of all light engines and available accessories check [www.supermodular.us](http://www.supermodular.us) or connect with your sales contact.