

Smart surface tubed wall 1.9 1x LED DE

US_129010XX

INSTALLATION WITH 4X4 OCTAGONAL JUNCTION BOX

1A

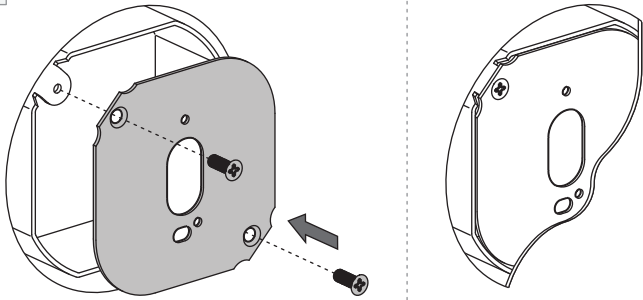

JUNCTION BOX NOT INCLUDED



2A

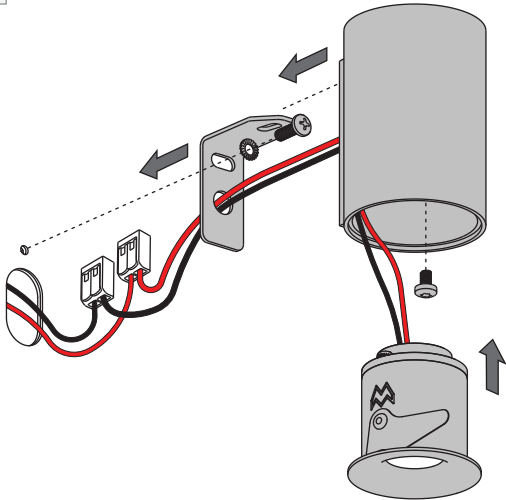

INSTALLATION WITHOUT JUNCTION BOX

1B

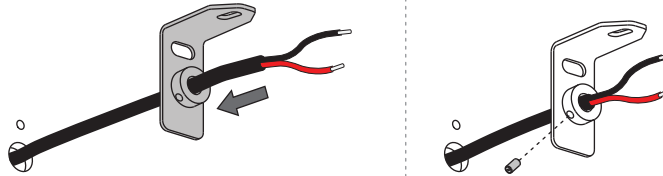

2B

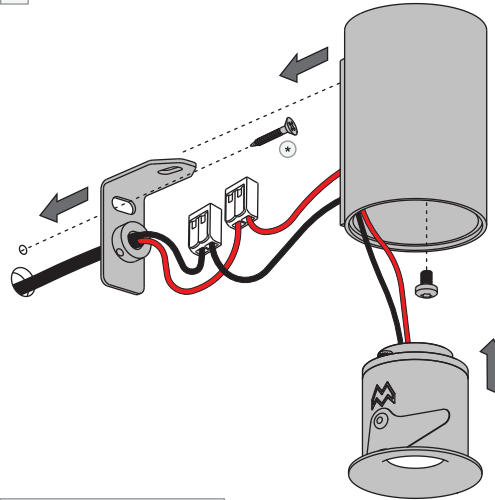

SCREW NOT INCLUDED



3

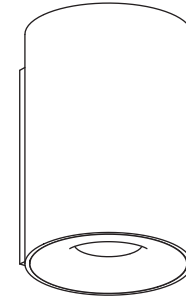

LED LUMINAIRE ACCESSORY

IMPORTANT SAFETY INSTRUCTIONS

- Read all instructions.
- Save these instructions.

BASIC SAFETY PRECAUTIONS

- Suitable for damp locations.
- Min. 90°C supply conductors.

LIGHT SOURCE - DO NOT TOUCH LED



Touching the LED can result in permanent damage of the light source. The light source contained in this luminaire shall only be replaced by the manufacturer or his service agent or a similar qualified person.

PREVENTING ELECTROSTATIC DAMAGE



A discharge of static electricity may damage sensitive components. Always be properly grounded when touching leads or circuitry inside the luminaire. Use a wrist strap connected by a ground cord to the housing. Avoid touching the light sources with bare hands.

MUST BE COMBINED WITH

(NOT INCLUDED)

- light engine: Smart 1.9 + LED DE (1x)

LIGHT ENGINES, POWER SUPPLIES & ACCESSORIES

For latest version of all light engines, power supplies and available accessories check www.supermodular.us or connect with your sales contact.

ELECTRICAL CONNECTION (RATINGS - SEE INDIVIDUAL MANUAL)

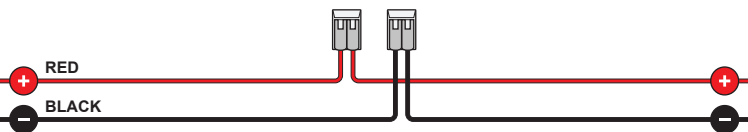

- MAX 500mA DC
- RESPECT POLARITY
- 0" 13/32 (11mm)
- 0.2 - 4mm²
- 24 - 12 AWG

MOUNTING HOLES

