

# Backplate 3x2 Smart Tube Wall 1.9 1x

US\_120534XX

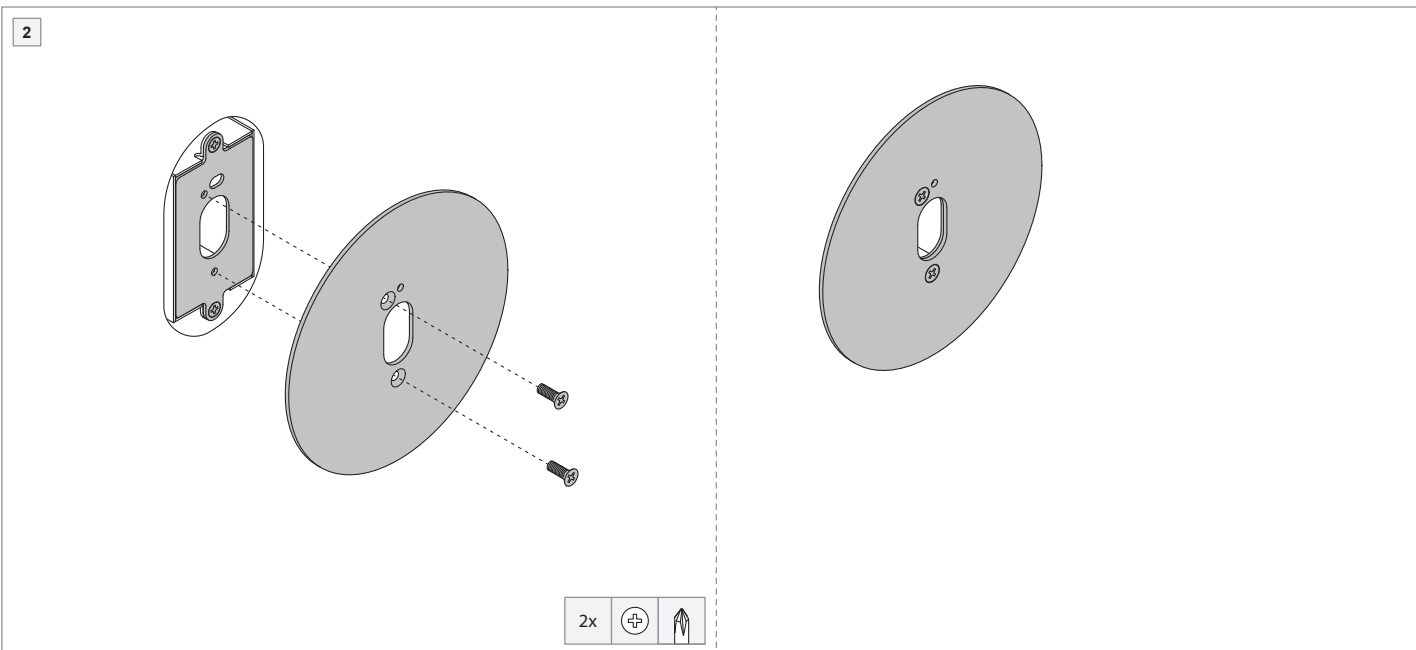

## LUMINAIRE MOUNTING HOLES (SEE INDIVIDUAL INSTRUCTION FOR INSTALLATION)

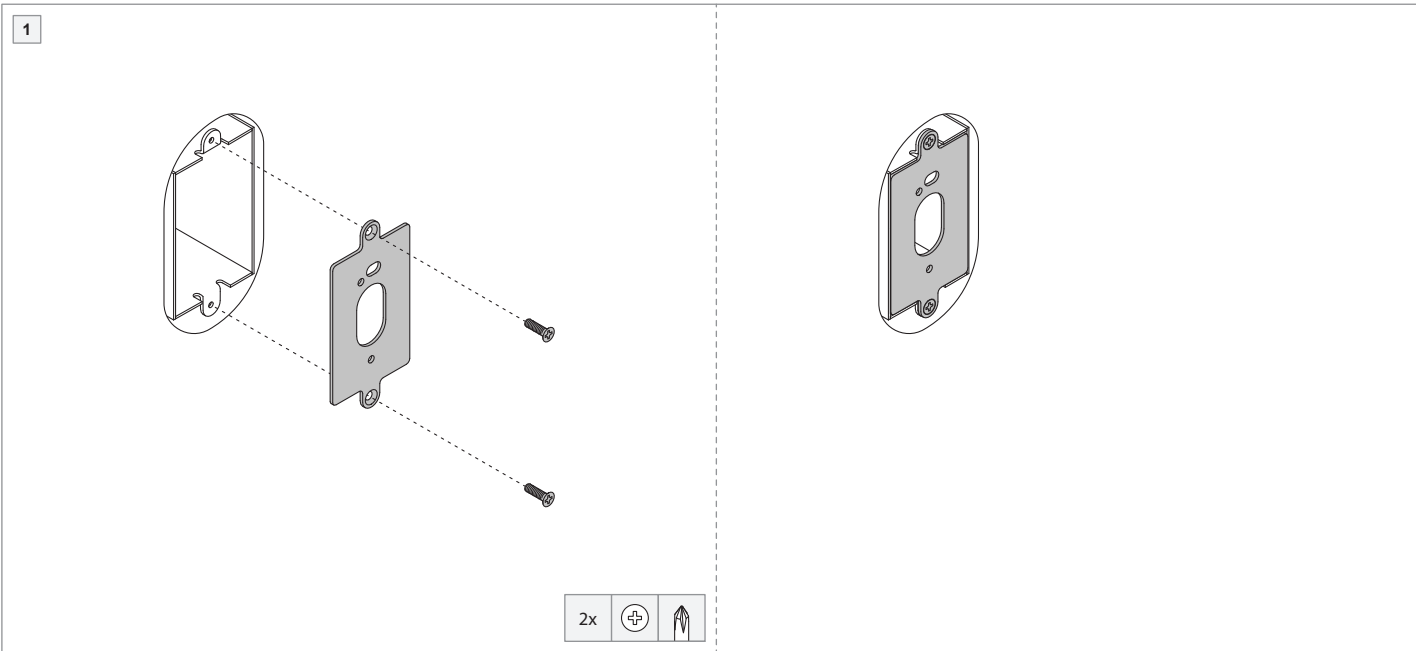
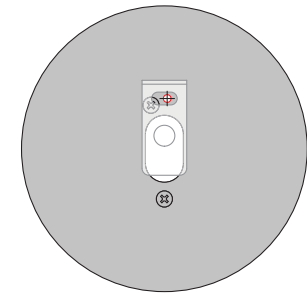

### INSTALLATION INSTRUCTION (ACCESSORY)

- Read all instructions.
- Save these instructions.

**PAINTING**  
The backplate (cover) can be painted in the field to match the color of the wall.  
Connect with your sales contact for detailed information.

### MUST BE COMBINED WITH (NOT INCLUDED)

- Smart Tube Wall 1.9 1x DE

### LUMINAIRES & ACCESSORIES

For latest version of all available luminaires and accessories, check [www.supermodular.com](http://www.supermodular.com) or connect with your sales contact.

